

| | | | |
|---------------------------|------------------------|-----------------------------|---|
| LOC I-FND 111.7 | APP CRS 155° | Rwy Idg TDZE Apt Elev | 8301 138 146 |
|---------------------------|------------------------|-----------------------------|---|

BALTIMORE/
WASHINGTON INTL THURGOOD MARSHALL (BWI) **ILS or LOC RWY 15R**

Simultaneous approach authorized with Rwy 15L. DME or Radar required. DME from BAL VORTAC.
RVR 1800 authorized with use of FD or AP or HUD to DA.

MALS R

MISSED APPROACH: Climb to 900 then climbing right turn to 2600 on BAL VORTAC R-294 to DATED INT/BAL 14.9 DME and hold.

| | | | | |
|------------------------------|---|---------------------------------------|-------------------------|---------------------------|
| D-ATIS 115.1 127.8 | POTOMAC APP CON (020°-100°) 119.7 290.475 (131°-180°) (101°-130°) 128.7 307.9 (181°-019°) | BALTIMORE TOWER 119.4 257.8 | GND CON 121.9 | CLNC DEL 118.05 |
|------------------------------|---|---------------------------------------|-------------------------|---------------------------|

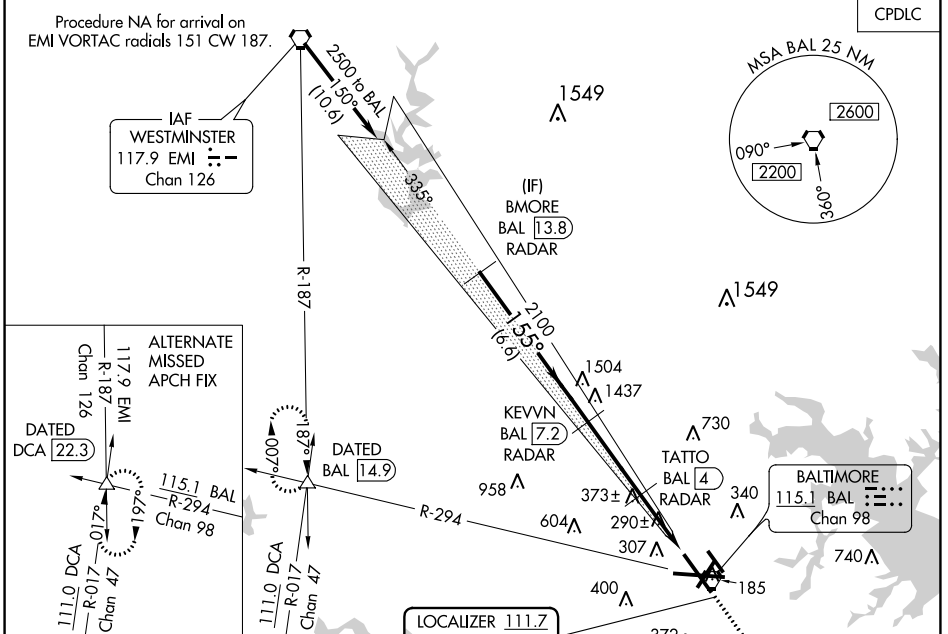

| | | |
|----------|----------|----------|
| ELEV 146 | D | TDZE 138 |
|----------|----------|----------|

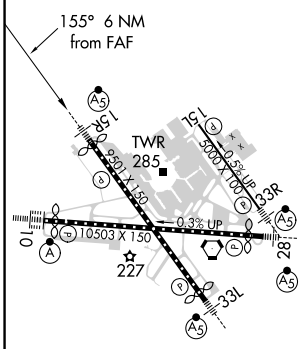

TDZ/CL Rwy 10 and 33L
REIL Rwy 15L and 33R
HIRL all rwy

FAF to MAP 6 NM

| | | | | | |
|---------|------|------|------|------|------|
| Knots | 60 | 90 | 120 | 150 | 180 |
| Min:Sec | 6:00 | 4:00 | 3:00 | 2:24 | 2:00 |

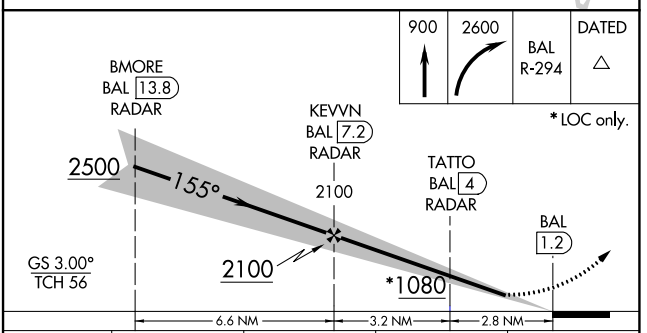

| | | | | |
|-------------------|----------------------|----------------------|------------------------|------------------------|
| CATEGORY | A | B | C | D |
| S-ILS 15R | | #338/24 | 200 (200-½) | |
| S-LOC 15R | 540/24 | 402 (400-½) | 540/40 | 402 (400-¾) |
| C CIRCLING | 640-1 494 (500-1) | 660-1 514 (600-1) | 700-1½ 554 (600-1½) | 880-2¼ 734 (800-2¼) |

NE-3, 07 OCT 2021 to 04 NOV 2021

NE-3, 07 OCT 2021 to 04 NOV 2021