

LOC I-DAY 108.3	APP CRS 185°	Rwy Idg 8502
		TDZE 996
		Apt Elev 1009

ILS or LOC RWY 18

JAMES M COX DAYTON INTL (DAY)

▼ For inop ALS, increase S-LOC 18 Cat C/D visibility to RVR 6000.
**** RVR 1800 authorized with the use of FD or AP or HUD to DA.**

MALSR

MISSED APPROACH: Climb to 1400 then climbing right turn to 3100 direct DQN VOR/DME and hold.

ATIS 125.8	COLUMBUS APP CON 118.425 323.15	DAYTON TOWER 119.9 257.7	GND CON 121.9	CINC DEL 121.75
----------------------	---	------------------------------------	-------------------------	---------------------------

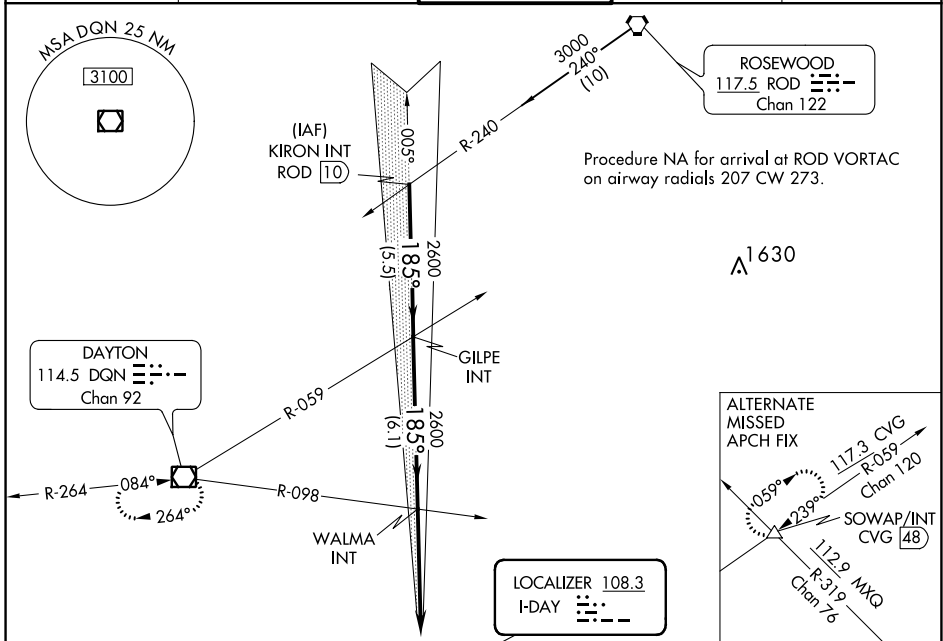

ELEV 1009	D	TDZE 996
-----------	----------	----------

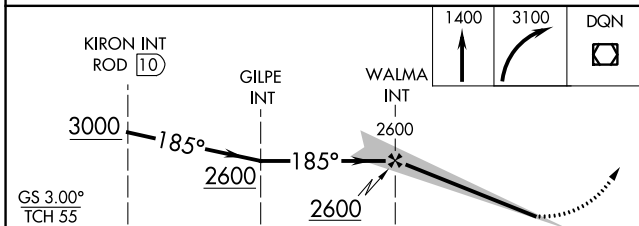

	5.5 NM	6.1 NM	4.9 NM	
CATEGORY	A	B	C	D
S-ILS 18 **	1196/24 200 (200-½)			
S-LOC 18	1400/24	404 (400-½)	1400/40	404 (400-¾)
C CIRCLING	1580-1	571 (600-1)	1580-1½ 571 (600-1½)	1640-2 631 (700-2)

