

WAAS CH <b>73025</b> <b>W27A</b>	APP CRS <b>272°</b>	Rwy Idg TDZE <b>925</b> Apt Elev <b>925</b>
--	------------------------	---

# RNAV (GPS) RWY 27

PORTLAND MUNI (PLD)

RNP APCH - GPS.	<p><b>▽</b> Rwy 27 helicopter visibility reduction below 1 SM NA. <b>▲</b> Straight-in Rwy 27 NA at night, Circling Rwy 27 NA at night.</p>	<p>MISSED APPROACH: Climb to 2500 direct DIYEC and hold.</p>

AWOS-3 <b>124.675</b>	FORT WAYNE APP CON <b>132.15 (SE/NE) 284.6</b> <b>127.2 (SW/NW) 284.6</b>	UNICOM <b>122.8 (CTAF) 0</b>
--------------------------	---	---------------------------------

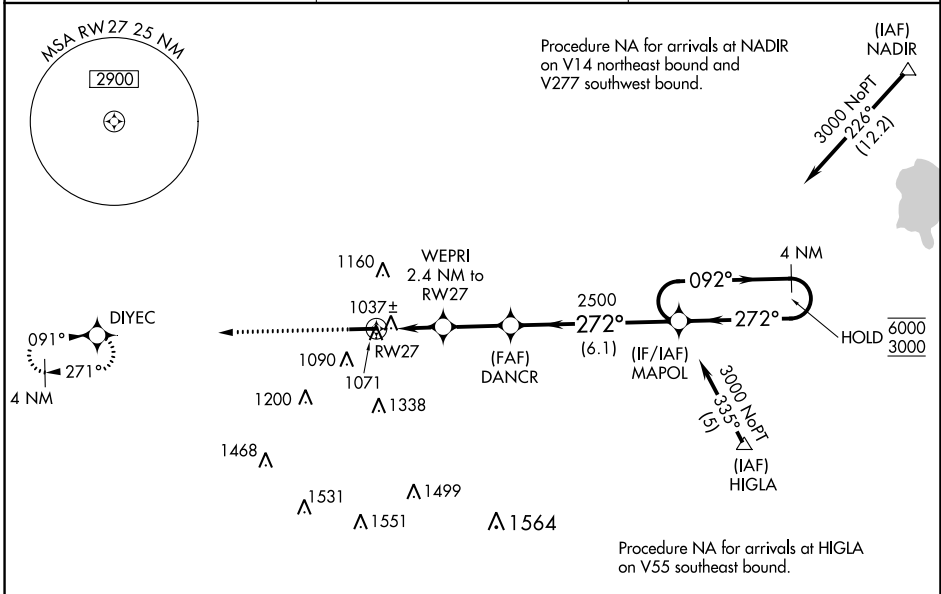

ELEV 925	TDZE 925
----------	----------

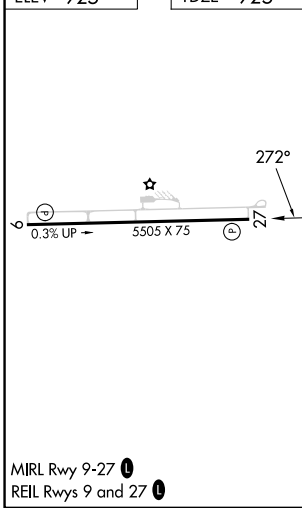

2500	DIYEC	VGSI and descent angles not coincident (VGSI Angle 3.00/TCH 26).	4 NM Holding Pattern	
RWY 27	WEPRI 2.4 NM to RWY 27	DANCR	MAPOL	
2.4 NM	2.5 NM	6.1 NM		
CATEGORY	A	B	C	D
LP MDA	1300-1 375 (400-1)			
LNAV MDA	1380-1	455 (500-1)	1380-1 <sup>3</sup> / <sub>8</sub>	455 (500-1 <sup>3</sup> / <sub>8</sub> )
CIRCLING	1480-1	555 (600-1)	1580-1 <sup>3</sup> / <sub>4</sub>	1640-2 <sup>1</sup> / <sub>4</sub> 655 (700-1 <sup>3</sup> / <sub>4</sub> ) 715 (800-2 <sup>1</sup> / <sub>4</sub> )

EC-2, 11 JUL 2024 to 08 AUG 2024

EC-2, 11 JUL 2024 to 08 AUG 2024