

| | | |
|--|------------------------|--|
| VORTAC RMG 115.4 Chan 101 | APP CRS 108° | Rwy ldg TDZE Apt Elev 5233 1028 1040 |
|--|------------------------|--|

VOR/DME RWY 9

COBB COUNTY INTL/MCCOLLUM FLD (RYY)

⚠ Helicopter visibility reduction below 1 SM NA. When local altimeter setting not received, use Hartsfield-Jackson Atlanta Intl altimeter setting and increase all MDA 60 feet and S-9 Cat A/C/D visibilities ¼ mile. Night landing: Rwy 9 NA.

MISSED APPROACH: Climbing left turn to 3000 via heading 240° and RMG R-108 to KAILA/21 DME and hold.

| | | | | | | |
|------------------------|---------------------------------------|---|-------------------------|--------------------------|---|------------------------|
| ATIS 128.125 | ATLANTA APP CON 121.0 268.7 | MCCOLLUM TOWER ★ 125.9 (CTAF) 0 | GND CON 119.0 | CLNC DEL 119.0 | CLNC DEL 121.0 268.7 (When twr closed) | UNICOM 122.7 |
|------------------------|---------------------------------------|---|-------------------------|--------------------------|---|------------------------|

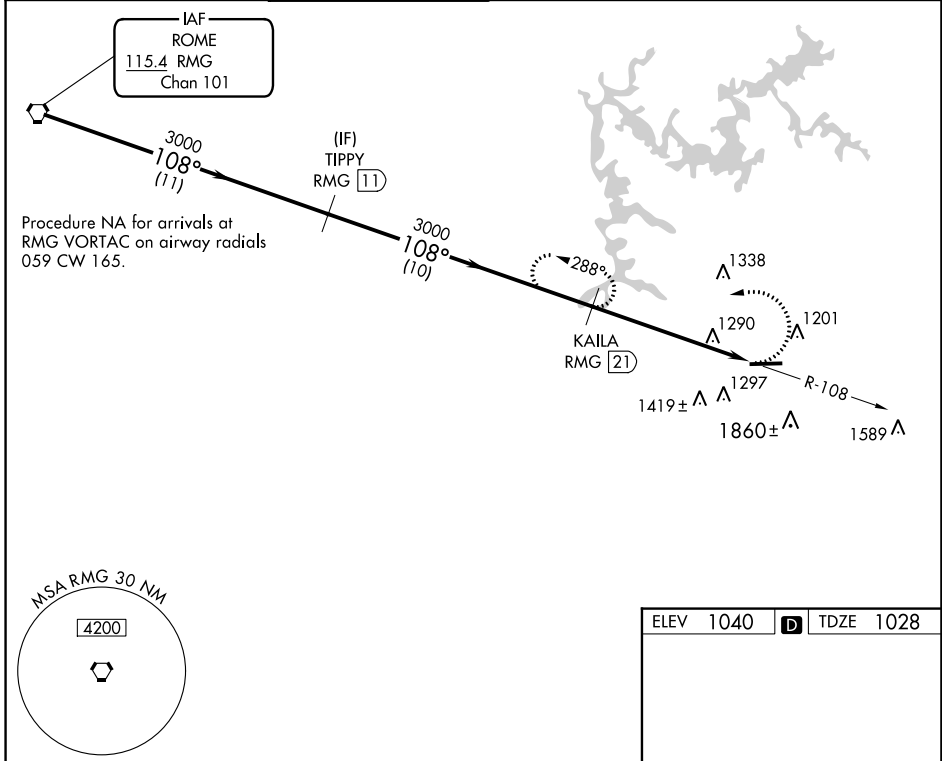

| | | | | | |
|--|-----------------------|-------------------------|-------------------------|-------------------------------|----------------|
| | RMG VORTAC | TIPPY RMG (11) | KAILA RMG (21) | 3000 hdg 240° RMG R-108 | KAILA RMG (21) |
| Procedure Turn NA | 3000 | 3000 | 3000 | 3000 | 3000 |
| VGSI and descent angles not coincident (VGSI Angle 4.00/TCH 46). | | | 2.93° TCH 40 | | |
| | 11 NM | 10 NM | 6.2 NM | | |
| CATEGORY | A | B | C | D | |
| S-9 | 1900-1 872 (900-1) | 1900-1¼ 872 (900-1¼) | 1900-2½ 872 (900-2½) | 1900-2¾ 872 (900-2¾) | |
| CIRCLING | 1900-1¼ | 860 (900-1¼) | 2220-3 | 1180 (1200-3) | |

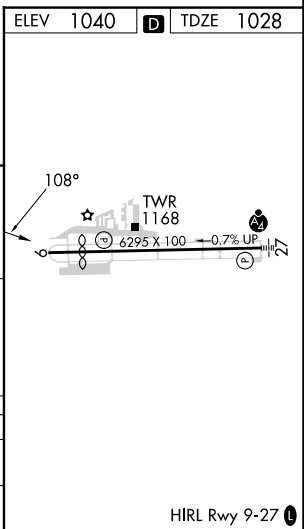

SE-4, 11 JUL 2024 to 08 AUG 2024

SE-4, 11 JUL 2024 to 08 AUG 2024