

APP CRS <b>260°</b>	Rwy ldg TDZE Apt Elev	<b>3499</b> <b>832</b> <b>833</b>
------------------------	-----------------------------	---

# RNAV (GPS) RWY 26

KNOXVILLE DOWNTOWN ISLAND (DKX)

RNP APCH - GPS.		MISSED APPROACH: Climb to 4000 direct SWASO and hold.	
▼ ▲ Rwy 26 helicopter visibility reduction below 3/4 SM NA.		AWOS-3 <b>125.375</b>	KNOXVILLE APP CON <b>123.9 353.6</b>
		CINC DEL <b>121.7</b>	UNICOM <b>123.075 (CTAF)</b> <b>0</b>

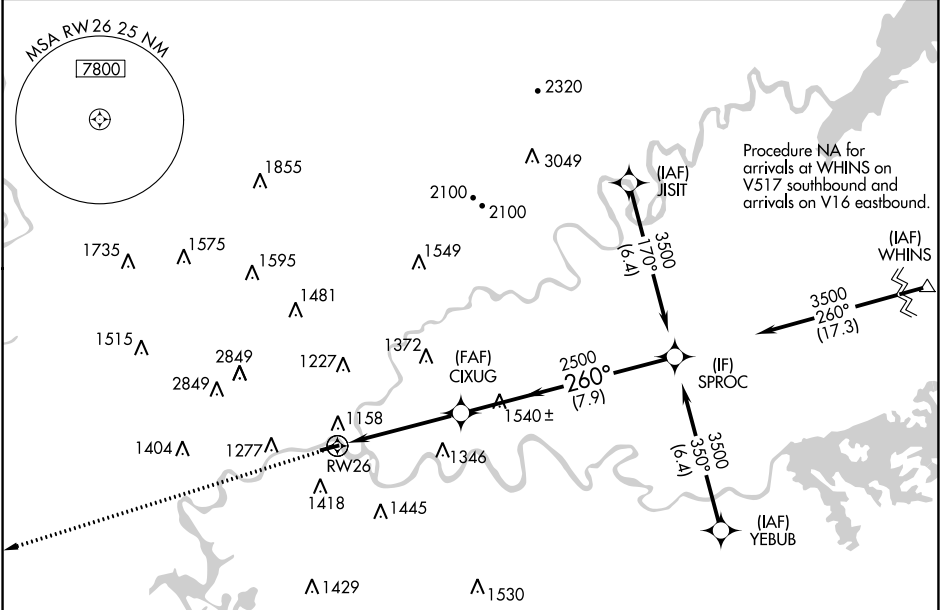

SE-1, 05 SEP 2024 to 03 OCT 2024

SE-1, 05 SEP 2024 to 03 OCT 2024

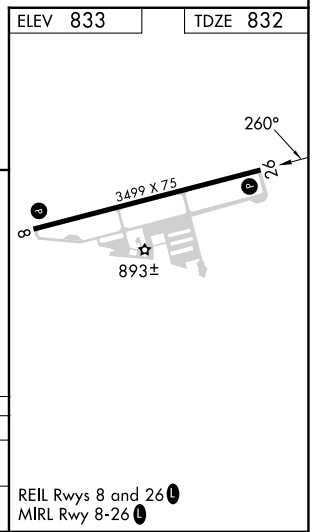
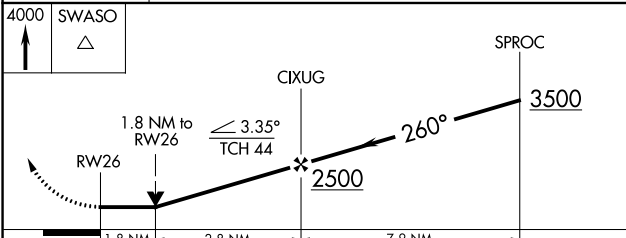
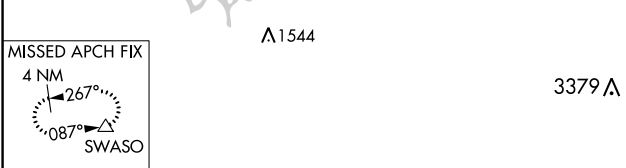

CATEGORY	A	B	C	D
LNVA MDA	1520-1	688 (700-1)	1520-2 688 (700-2)	NA
CIRCLING	1600-1 767 (800-1)	1720-1¼ 887 (900-1¼)	1720-2¾ 887 (900-2¾)	NA

REIL Rwy 8 and 26 **0**  
MIRL Rwy 8-26 **0**