

MINNEAPOLIS APP CON
126.35 335.5
D-ATIS ARR
135.35 239.275

(MUSCL.MUSCL3) 17173
MINNEAPOLIS-ST PAUL INTL/WOLD-CHAMBERLAIN (MSP)
Transition Routes AL-264 (FAA) MINNEAPOLIS, MINNESOTA

MUSCL THREE ARRIVAL (RNAV) Transition Routes
(MUSCL.MUSCL3) 051ANI7
MINNEAPOLIS, MINNESOTA
MINNEAPOLIS-ST PAUL INTL/WOLD-CHAMBERLAIN (MSP)

See following page
for Arrival Routes.

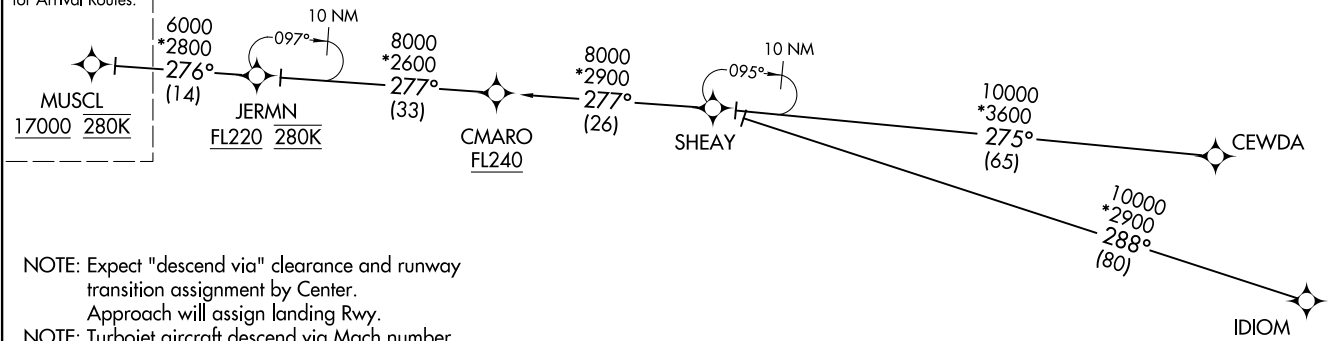

- NOTE: Expect "descend via" clearance and runway transition assignment by Center. Approach will assign landing Rwy.
- NOTE: Turbojet aircraft descend via Mach number until intercepting 280K. Maintain 280K until slowed by the STAR, or assigned by ATC.
- NOTE: DME/DME/IRU or GPS required.
- NOTE: For turbojet aircraft only.
- NOTE: RADAR required.
- NOTE: RNAV 1.

- CEWDA TRANSITION (CEWDA.MUSCL3)
- CMARO TRANSITION (CMARO.MUSCL3)
- IDIOM TRANSITION (IDIOM.MUSCL3)
- JERMN TRANSITION (JERMN.MUSCL3)
- SHEAY TRANSITION (SHEAY.MUSCL3)

(CONTINUED ON FOLLOWING PAGE)



NOTE: Chart not to scale.

MUSCL THREE ARRIVAL (RNAV) Arrival Routes
 (MUSCL,MUSCL3) 05JAN17
 MINNEAPOLIS-ST PAUL INTL/WOLD-CHAMBERLAIN (MSP)
 MINNEAPOLIS, MINNESOTA

MINNEAPOLIS APP CON
 126.35 335.5
 D-ATIS ARR
 135.35 239.275



NOTE: Expect "descend via" clearance and runway transition assignment by Center.
 Approach will assign landing Rwy.
 NOTE: Turbojet aircraft descend via Mach number until intercepting 280K.
 Maintain 280K until slowed by the STAR, or assigned by ATC.
 NOTE: DME/DME/IRU or GPS required.
 NOTE: For turbojet aircraft only.
 NOTE: RADAR required.
 NOTE: RNAV 1.

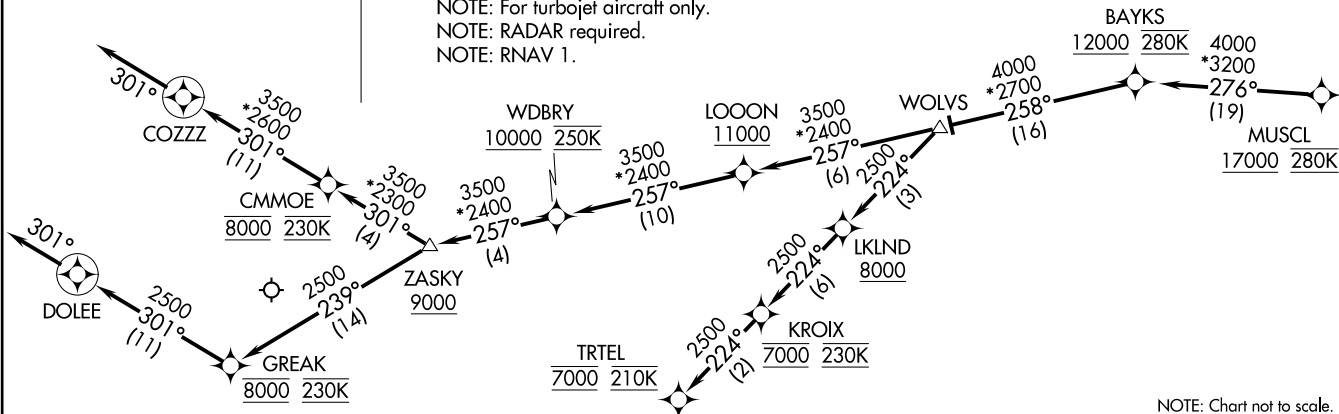

NOTE: Chart not to scale.

ARRIVAL ROUTE DESCRIPTION

From MUSCL on track 276° to cross BAYKS at or above 12000 and at 280K, then on track 258° to WOLVS.

LANDING RUNWAYS 4, 12L, 17, 22: From WOLVS on track 257° to cross LOOON at or above 11000, then on track 257° to cross WDBRY at or above 10000 and at 250K, then on track 257° to cross ZASKY at or above 9000, then on track 301° to cross CMMOE at 8000 and at 230K, then on track 301° to COZZZ, then on track 301°. Expect RADAR vectors to final approach course.

LANDING RUNWAYS 12R, 35: From WOLVS on track 257° to cross LOOON at or above 11000, then on track 257° to cross WDBRY at or above 10000 and at 250K, then on track 257° to cross ZASKY at or above 9000, then on track 239° to cross GREAK at 8000 and at 230K, then on track 301° to DOLEE, then on track 301°. Expect RADAR vectors to final approach course.

LANDING RUNWAYS 30L/R: From WOLVS on track 224° to cross LKLND at or above 8000, then on track 224° to cross KROIX at 7000 and at 230K, then on track 224° to cross TRTEL at 7000 and at 210K. Expect RNAV (RNP), RNAV (GPS), or ILS approach or RADAR vectors to final approach course.

(MUSCL,MUSCL3) 17173
 MUSCL THREE ARRIVAL (RNAV) Arrival Routes
 AL-264 (FAA) MINNEAPOLIS, MINNESOTA
 MINNEAPOLIS-ST PAUL INTL/WOLD-CHAMBERLAIN (MSP)