

APP CRS	Rwy Idg	<b>5004</b>
<b>093°</b>	TDZE	<b>1184</b>
	Apt Elev	<b>1184</b>

# RNAV (GPS) RWY 9

WASHINGTON COUNTY (A.FJ)

RNP APCH - GPS.	MISSED APPROACH: Climb to 3000 direct KEYRE and hold.
<b>▼</b> Circling NA for Cat D N of Rwy 9-27. Rwy 9 helicopter visibility reduction below 1 SM NA.	

AWOS-3PT <b>119.175</b>	PITTSBURGH APP CON <b>119.35 285.575</b>	CLNC DEL <b>127.3</b>	UNICOM <b>122.975 (CTAF) 0</b>
----------------------------	---	--------------------------	-----------------------------------

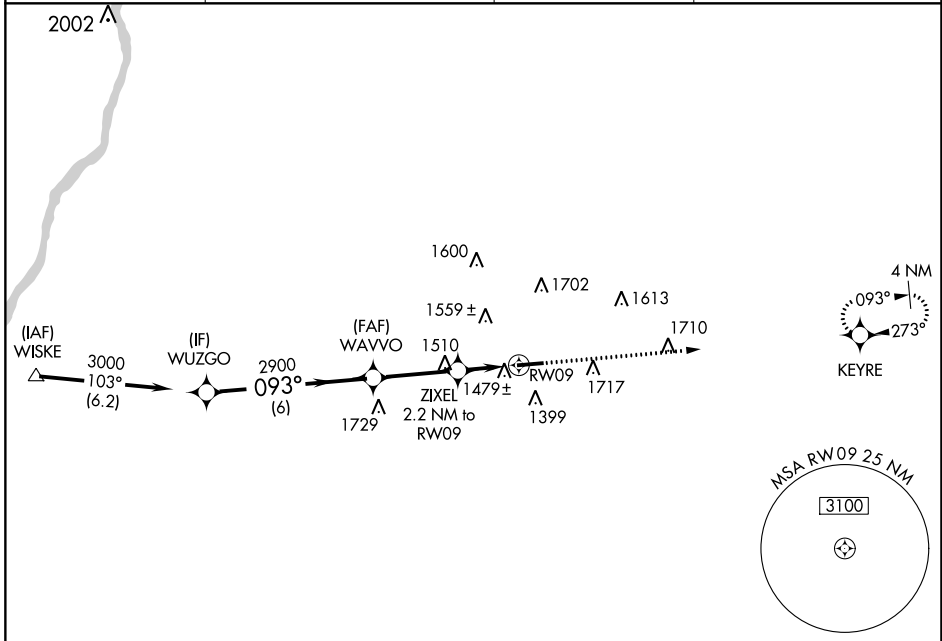

NE-4, 31 OCT 2024 to 28 NOV 2024

NE-4, 31 OCT 2024 to 28 NOV 2024

ELEV 1184	TDZE 1184
-----------	-----------

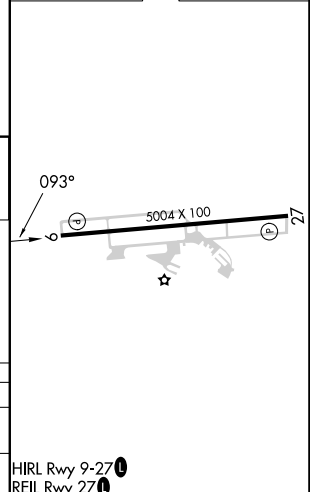

CATEGORY	A	B	C	D
LNVA MDA	1740-1	556 (600-1)	1740-1½	556 (600-1½)
<b>C</b> CIRCLING	1800-1 616 (700-1)	2020-1¼ 836 (900-1¼)	2020-2½ 836 (900-2½)	2040-2¾ 856 (900-2¾)