

WAAS CH 73041 W26A	APP CRS 260°	Rwy Idg TDZE 46 Apt Elev 49	5900
--	------------------------	---	-------------

RNAV (GPS) RWY 26

WILEY POST-WILL ROGERS MEML (BRW)(PABR)

RNP APCH - GPS.	MISSED APPROACH: Climb to 2000 direct OBCIN and hold.
<p>▼ For uncompensated Baro-VNAV systems, LNAV/VNAV ▲ NA below -19°C or above 54°C. Circling NA for Cat A north of Rwy 8-26</p>	

AFIS 132.15	ANCHORAGE CENTER 135.3 239.25	BARROW RADIO 123.6 (CTAF) 0
-----------------------	---	---------------------------------------

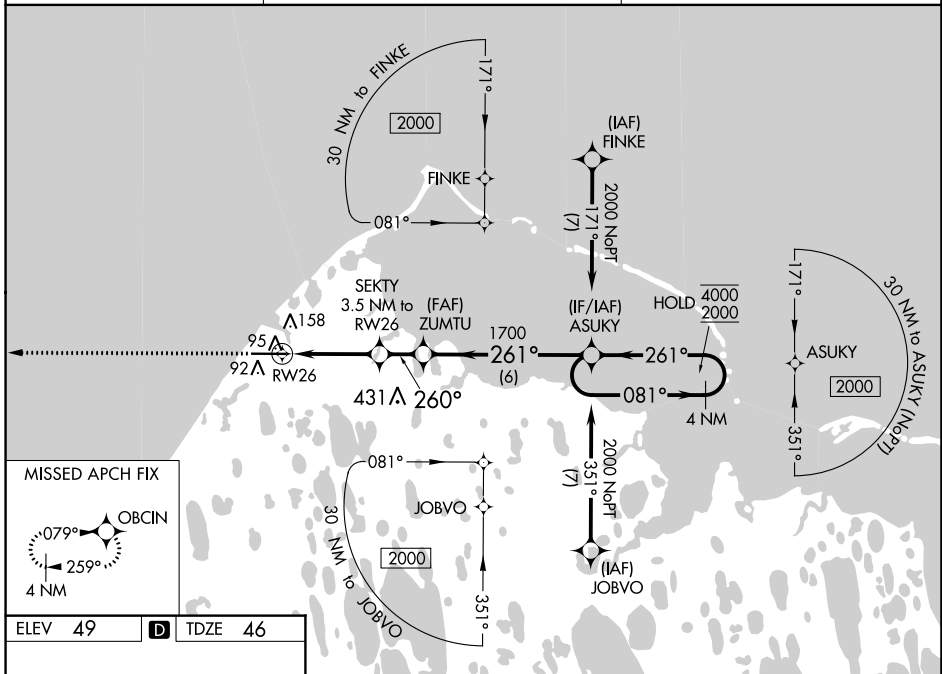

ELEV 49	D TDZE 46
----------------	-------------------------

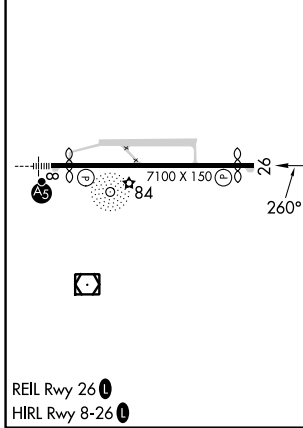
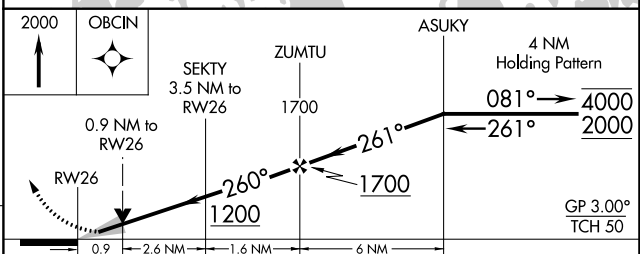

CATEGORY	A	B	C	D
LPV DA		246-1	200 (200-1)	
LNAV/VNAV DA		296-1	250 (300-1)	
LNAV MDA		360-1	314 (400-1)	
C CIRCLING	420-1 371 (400-1)	500-1 451 (500-1)	500-1½ 451 (500-1½)	680-2 631 (700-2)

AK, 31 OCT 2024 to 26 DEC 2024

AK, 31 OCT 2024 to 26 DEC 2024