

LOC I-DAY <b>108.3</b>	APP CRS <b>185°</b>	Rwy Idg TDZE Apt Elev	<b>8502</b> <b>996</b> <b>1009</b>
---------------------------	------------------------	-----------------------------	--

# ILS or LOC RWY 18

JAMES M COX DAYTON INTL (DAY)

▼ For inop ALS, increase S-LOC 18 Cat C/D visibility to RVR 6000.  
 \*\* RVR 1800 authorized with use of FD or AP or HUD to DA.

MALSR

MISSED APPROACH: Climb to 1400 then climbing right turn to 3100 direct DQN VOR/DME and hold.

ATIS <b>125.8</b>	COLUMBUS APP CON <b>134.45 323.15</b>	DAYTON TOWER <b>119.9 257.7</b>	GND CON <b>121.9</b>	CINC DEL <b>121.75</b>
----------------------	--	------------------------------------	-------------------------	---------------------------

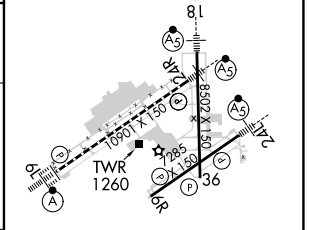
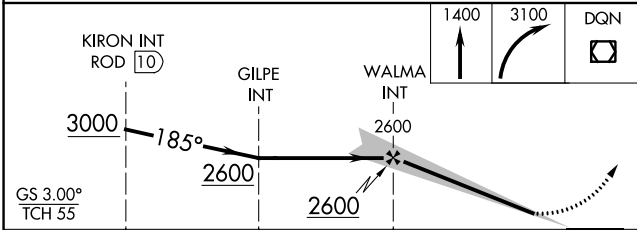
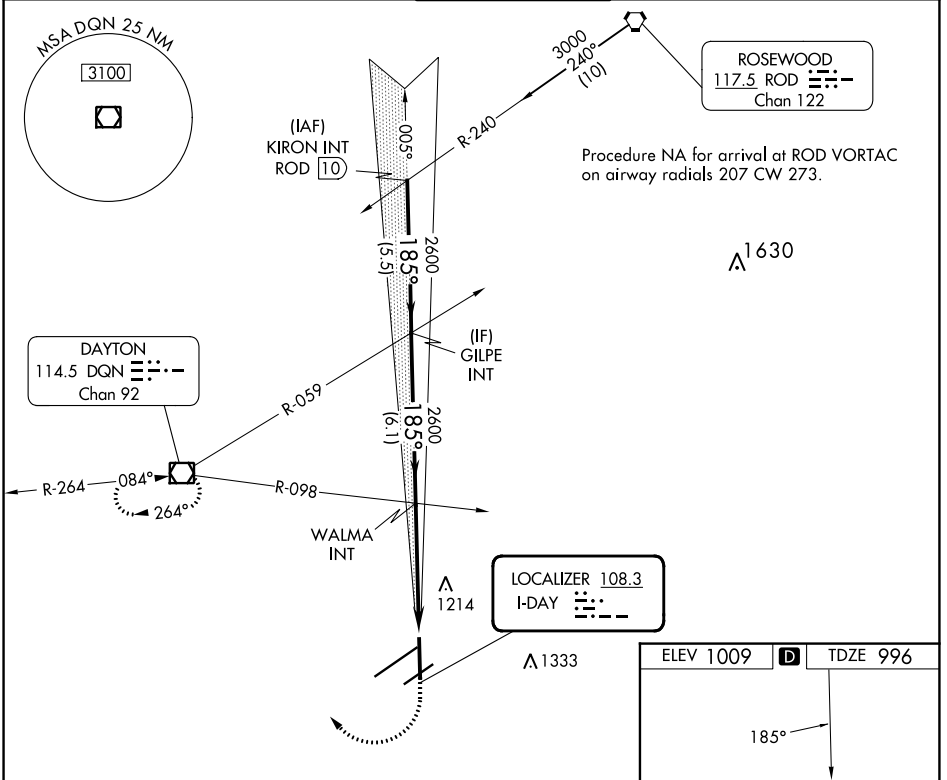

CATEGORY	A	B	C	D
S-ILS 18 **	1196/24 200 (200-½)			
S-LOC 18	1400/24	404 (400-½)	1400/40	404 (400-¾)
CIRCLING	1580-1	571 (600-1)	1580-1½ 571 (600-1½)	1640-2 631 (700-2)

HIRL all Rwys					
TDZ/CL Rwy 6L					
REIL Rwys 6R and 36					
FAF to MAP 4.9 NM					
Knots	60	90	120	150	180
Min:Sec	4:54	3:16	2:27	1:58	1:38

EC-2, 26 DEC 2024 to 23 JAN 2025

EC-2, 26 DEC 2024 to 23 JAN 2025