

WAAS CH 50300 W12A	APP CRS 122°	Rwy Idg TDZE Apt Elev	6001 74 79
--	------------------------	-----------------------------	---------------------------------------

RNAV (GPS) RWY 12

DELAND MUNI-SIDNEY H TAYLOR FLD (DED)

RNP APCH.

⚠ For uncompensated Baro-VNAV systems, LNAV/VNAV NA below -15°C (5°F) or above 54°C (130°F). Baro-VNAV and VDP NA when using Daytona Beach Intl altimeter setting. Rwy 12 helicopter visibility reduction below 3/4 SM NA. When local altimeter setting not received use Daytona Beach Intl altimeter setting increase all DA/MDA 40 feet, increase LNAV/VNAV visibility 1/4 SM all Cats.

MISSED APPROACH: Climb to 2000 direct CUGAK then on track 139° to OAKIE and hold.

AWOS-3 119.575	DAYTONA APP CON 125.35 322.3	UNICOM 123.075 (CTAF) 0
--------------------------	--	--

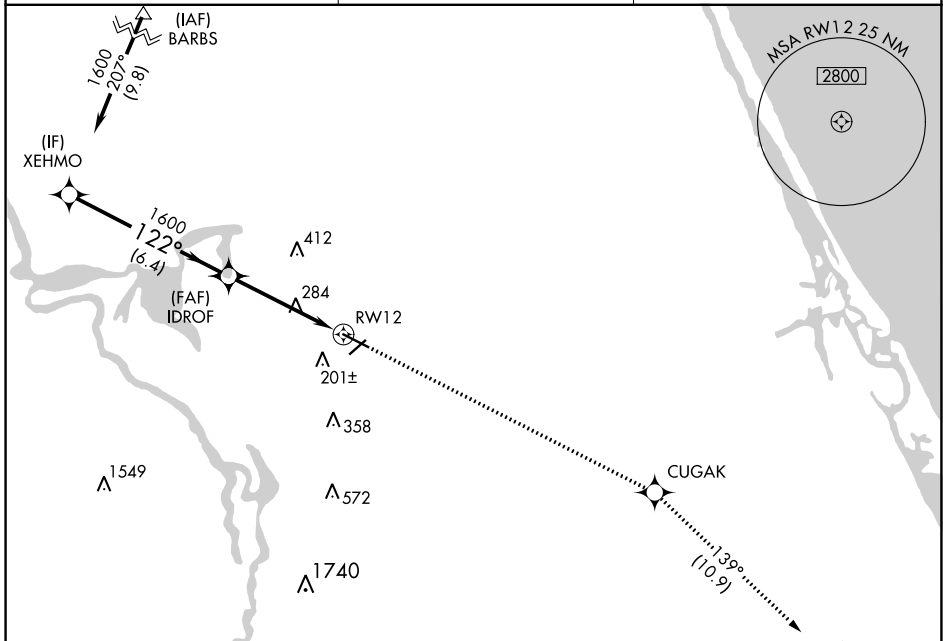

ELEV 79	TDZE 74
---------	---------

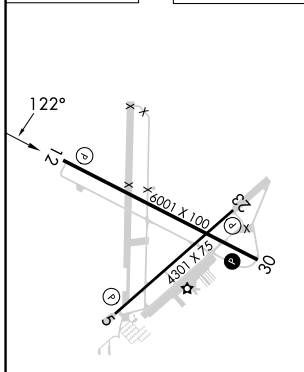

HIRL Rwy 12-30 **0**
MIRL Rwy 5-23 **0**
REIL Rwy 12 and 30 **0**

VGSI and RNAV glidepath not coincident (VGSI Angle 3.00/TCH 51).				
XEHMO	IDROF	2000 CUGAK	OAKIE	
1600	1600	tr 139°		
GP 3.00° TCH 40		*1.5 NM to RWY12	*LNAV only.	
6.4 NM		3.1 NM	1.5 NM	
CATEGORY	A	B	C	D
LPV DA	404-1 1/4 330 (400-1 1/4)			
LNAV/VNAV DA	528-1 1/2 454 (500-1 1/2)			
LNAV MDA	600-1	526 (600-1)	600-1 1/2	526 (600-1 1/2)

SE-3, 26 DEC 2024 to 23 JAN 2025

SE-3, 26 DEC 2024 to 23 JAN 2025