

APP CRS	Rwy Idg	4700
275°	TDZE	747
	Apt Elev	747

RNAV (GPS) RWY 27

DOWAGIAC MUNI (C91)

RNP APCH - GPS.

▼ Circling Rwy 9 NA at night. Rwy 27 helicopter visibility reduction below ¼ SM NA. VDP NA when using Elkhart altimeter setting. Obtain local altimeter setting on CTAF, when local altimeter setting not received, use Elkhart altimeter setting and increase all MDAs 60 feet and visibility Cat C and D ¼ SM.

MISSED APPROACH:
Climb to 2500 direct JUBLA and hold.

SOUTH BEND APP CON ★
118.55 257.8

UNICOM
122.8 (CTAF) 0

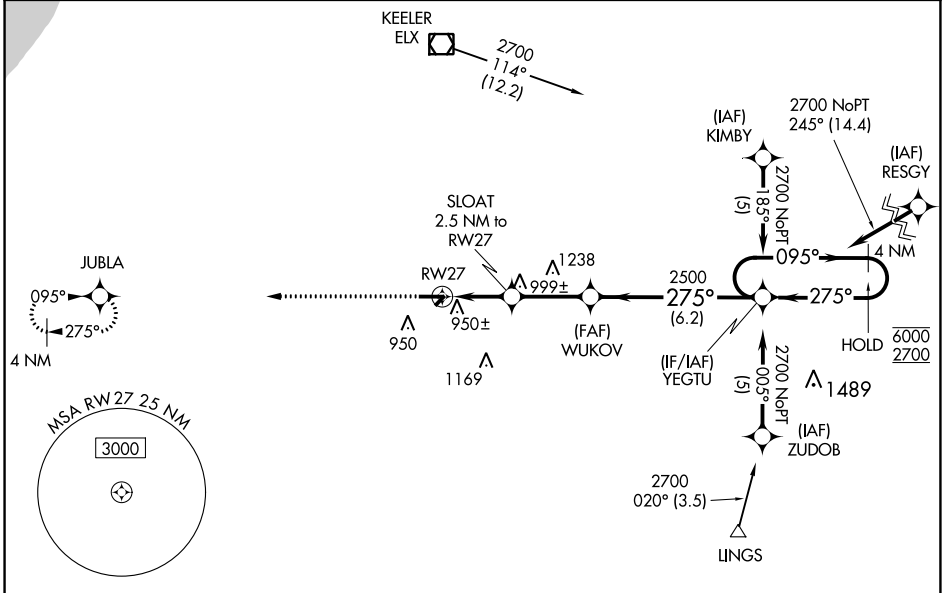

EC-1, 26 DEC 2024 to 23 JAN 2025

EC-1, 26 DEC 2024 to 23 JAN 2025

ELEV 747	TDZE 747
-----------------	-----------------

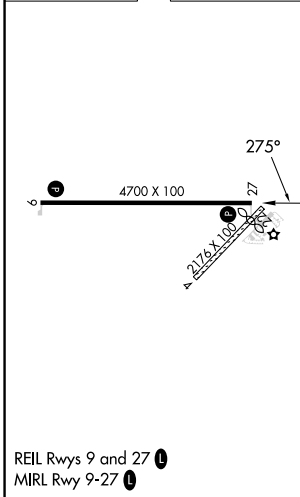

2500	JUBLA	4 NM Holding Pattern		
1580	WUKOV	YEGTU		
1.5	1 NM	2.8 NM	6.2 NM	
CATEGORY	A	B	C	D
RNAV MDA	1260-1	513 (600-1)	1260-1 ⅓	513 (600-1 ⅓)
CIRCLING	1320-1	573 (600-1)	1480-2	1480-2 ¼
			733 (800-2)	733 (800-2 ¼)

REIL Rwy 9 and 27 **0**
MIRL Rwy 9-27 **0**