

VOR/DME BSV <b>114.05</b> Chan <b>87 (Y)</b>	APP CRS <b>182°</b>	Rwy Idg TDZE Apt Elev <b>894</b>	<b>N/A</b> <b>N/A</b> <b>894</b>
--	------------------------	---	--

# VOR-A

HARRY CLEVER FLD (PHD)

DME or RADAR required.		MISSED APPROACH: Climb to 2100 then climbing left turn to 3000 direct BSV VOR/DME and hold.
<b>▽</b>	Circling NA to Rwys 12 and 30. Rwy 15, 33 helicopter visibility reduction below 1 SM	
<b>△</b>	NA. Procedure NA at night.	

ASOS <b>121.425</b>	CLEVELAND APP CON* <b>125.5 371.875</b>	UNICOM <b>122.8 (CTAF)</b>	<b>123.3 0</b>
------------------------	--	-------------------------------	----------------

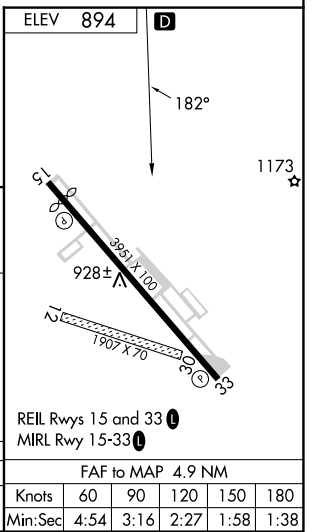
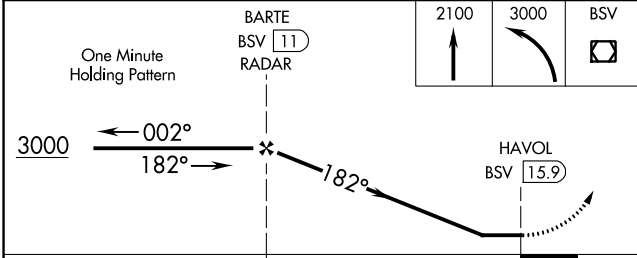
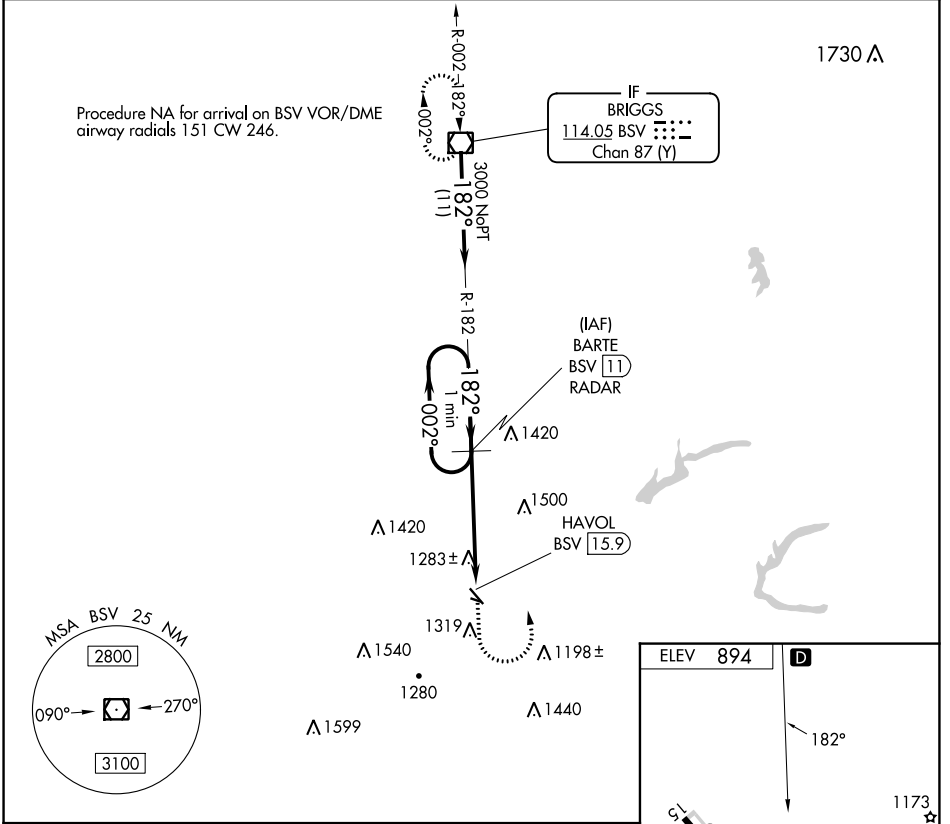

CATEGORY	A	B	C	D	FAF to MAP 4.9 NM						
<b>☐</b> CIRCLING	1720-1¼	826 (900-1¼)	1720-2½	826 (900-2½)	NA	Knots	60	90	120	150	180
						Min:Sec	4:54	3:16	2:27	1:58	1:38

# VOR-A

EC-2, 26 DEC 2024 to 23 JAN 2025

EC-2, 26 DEC 2024 to 23 JAN 2025