

WAAS CH <b>73025</b> <b>W27A</b>	APP CRS <b>272°</b>	Rwy Idg TDZE <b>925</b> Apt Elev <b>925</b>	<b>5505</b>
--	------------------------	---	-------------

# RNAV (GPS) RWY 27

PORTLAND MUNI (PLD)

RNP APCH - GPS.	<p><b>MISSED APPROACH:</b> Climb to 2500 direct DIYEC and hold.</p>
<p><b>▼</b> Rwy 27 helicopter visibility reduction below 1 SM NA. <b>▲</b> Straight-in Rwy 27 NA at night, Circling Rwy 27 NA at night.</p>	

AWOS-3 <b>124.675</b>	FORT WAYNE APP CON <b>132.15 (SE/NE) 284.6</b> <b>127.2 (SW/NW) 284.6</b>	UNICOM <b>122.8 (CTAF) 0</b>
--------------------------	---	---------------------------------

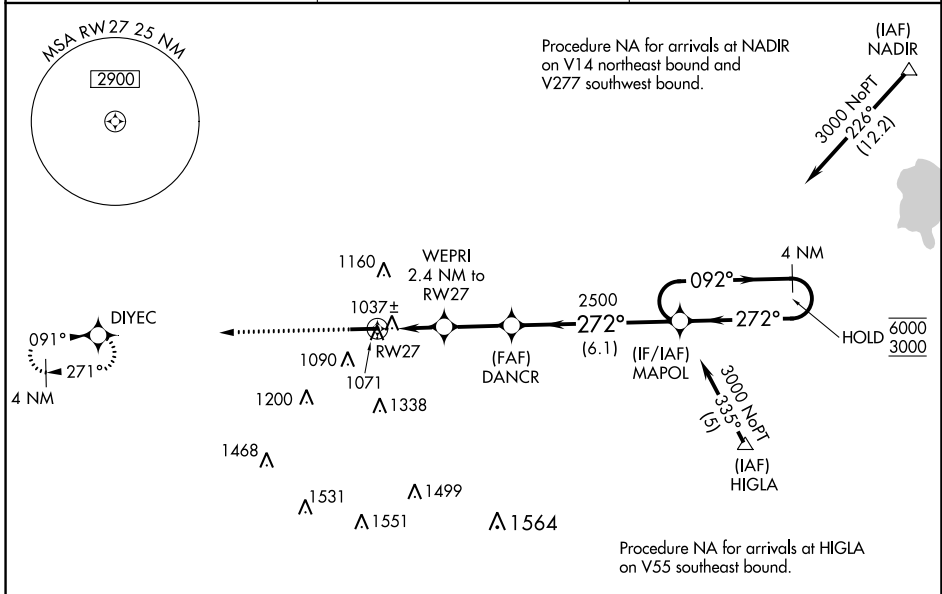

ELEV <b>925</b>	TDZE <b>925</b>
-----------------	-----------------

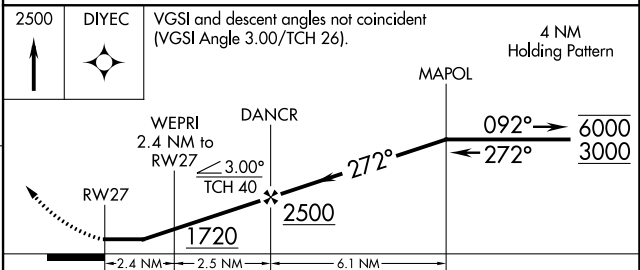
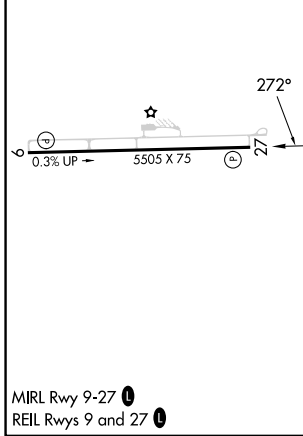

CATEGORY	A	B	C	D
LP MDA	1300-1 375 (400-1)			
LNAV MDA	1380-1	455 (500-1)	1380-1 $\frac{3}{8}$	455 (500-1 $\frac{3}{8}$ )
CIRCLING	1480-1	555 (600-1)	1580-1 $\frac{3}{4}$ 655 (700-1 $\frac{3}{4}$ )	1640-2 $\frac{1}{4}$ 715 (800-2 $\frac{1}{4}$ )

EC-2, 26 DEC 2024 to 23 JAN 2025

EC-2, 26 DEC 2024 to 23 JAN 2025