

WAAS CH <b>42737</b> <b>W27A</b>	APP CRS <b>271°</b>	Rwy Idg TDZE Apt Elev	<b>5001</b> <b>733</b> <b>738</b>
--	------------------------	-----------------------------	---

# RNAV (GPS) RWY 27

RANTOUL NTL AVN CNTR-FRANK ELLIOTT FLD (TIP)

**⚠** For uncompensated Baro-VNAV systems, LNAV/VNAV NA below -16°C (4°F) or above 54°C (130°F). DME/DME RNP-0.3 NA. When local altimeter setting not received, use Champaign Urbana altimeter setting and increase all DA 41 feet and all MDA 60 feet; increase LNAV/VNAV all Cats visibility 1/8 mile and LNAV and Circling Cats C/D visibility 1/4 mile. Baro-VNAV and VDP NA when using Champaign Urbana altimeter setting. Helicopter visibility reduction below 1/4 SM NA.

**MISSED APPROACH:**  
Climb to 3000 direct LEVVI and hold.

AWOS-3 <b>119.025</b>	CHAMPAIGN APP CON * <b>121.35 285.65</b>	UNICOM <b>123.0 (CTAF) 0</b>
--------------------------	---	---------------------------------

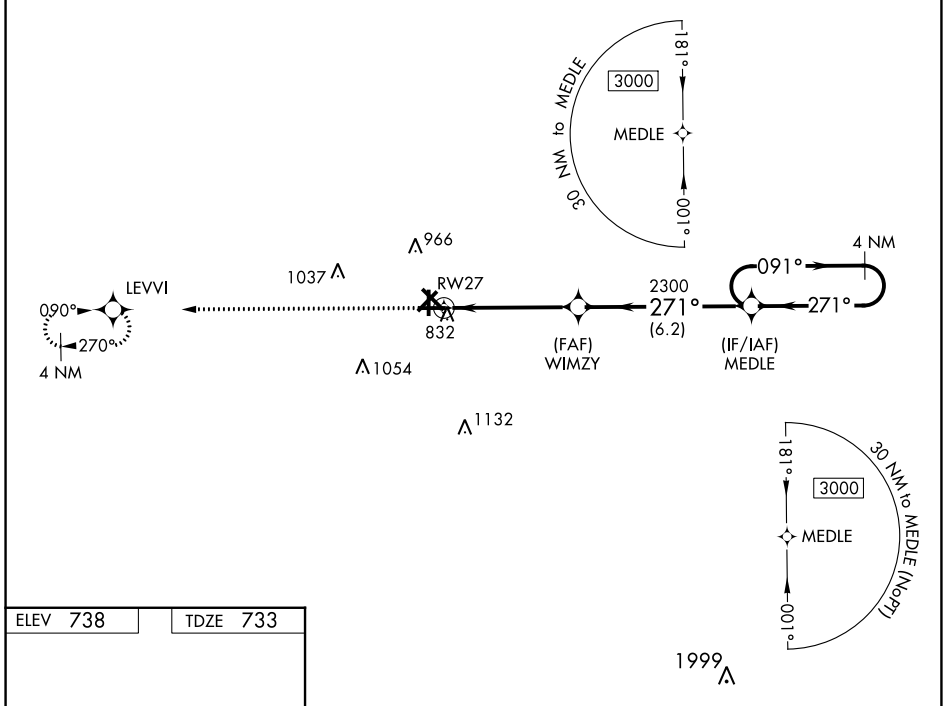

ELEV 738	TDZE 733
----------	----------

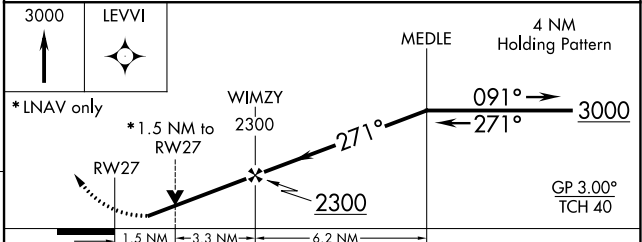
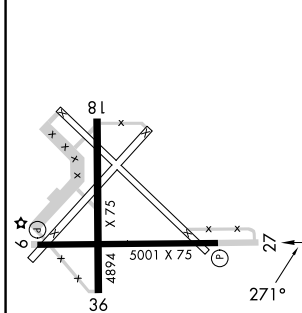

CATEGORY	A	B	C	D
LPV DA	983-1		250 (300-1)	
LNAV/VNAV DA	1029-1		296 (300-1)	
LNAV MDA	1240-1 507 (600-1)		1240-1 3/8 507 (600-1 3/8)	
<b>CIRCLING</b>	1240-1 502 (600-1)	1280-1 542 (600-1)	1380-1 3/4 642 (700-1 3/4)	1420-2 1/4 682 (700-2 1/4)

REIL Rwy 9 and 27 0  
MIRL Rwy 9-27 and 18-36 0