

BUCKEYE FOUR DEPARTURE  
(BXX4.BXX) 25JUN15

BUCKEYE FOUR DEPARTURE  
(BXX4.BXX) 23334

AL-322 (FAA)

PHOENIX SKY HARBOR INTL (PHX)  
PHOENIX, ARIZONA

PHOENIX DEP CON  
126.8 269.6  
D-ATIS  
127.575  
CLNC DEL  
118.1 269.2  
CPDLC  
GND CON  
119.75 269.2 (NORTH)  
132.55 269.2 (SOUTH)  
PHOENIX TOWER  
118.7 278.8 (Rwy 8-26)  
120.9 254.3 (Rwys 7L-25R, 7R-25L)

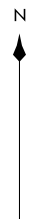

**TOP ALTITUDE:  
8000**

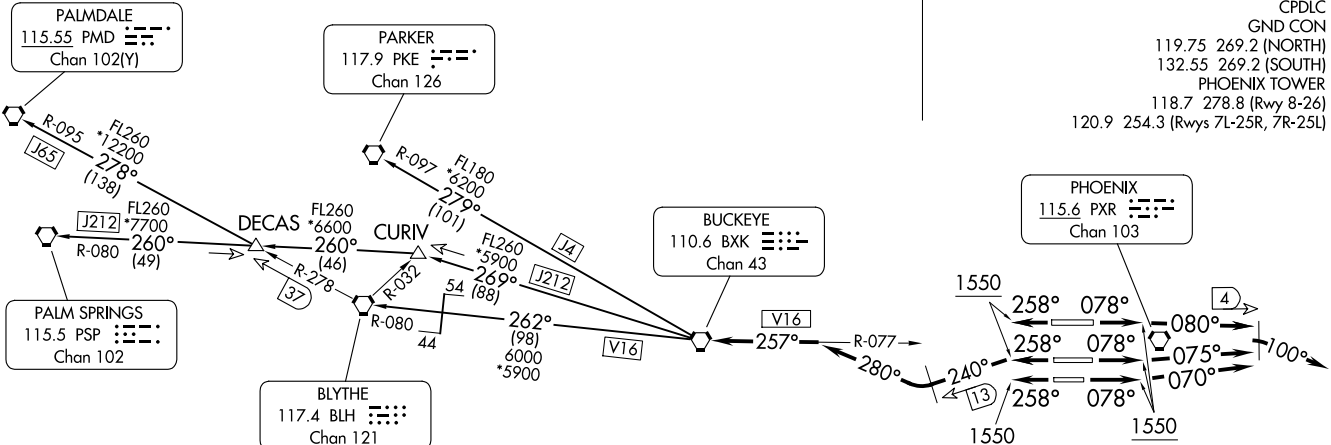

**TAKEOFF MINIMUMS**  
Rwys 7L/7R/8: Standard with minimum climb of 300' per NM to 8000.  
Rwys 25L/25R/26: Standard with minimum climb of 350' per NM to 8000.

- NOTE: Restricted to turbojet and turboprop aircraft only.
- NOTE: RADAR and DME required.
- NOTE: Aircraft requesting FL 220 and below must file BLYTHE Transition.
- NOTE: Turbojets landing LAX, file PARKER Transition.
- NOTE: Aircraft landing other than LAX and turboprops landing at LAX:  
Requesting FL240 and above, file PALMDALE or PALM SPRINGS Transition.

NOTE: Chart not to scale.

(CONTINUED ON FOLLOWING PAGE)

PHOENIX, ARIZONA  
PHOENIX SKY HARBOR INTL (PHX)



DEPARTURE ROUTE DESCRIPTION

TAKEOFF RUNWAY 8: Climb heading 078° to 1550, then climbing right turn heading 080°, at 4 DME east of PXR VORTAC, climbing right turn heading 100°. Expect RADAR vectors to BXX VORTAC. Thence . . . .

TAKEOFF RUNWAY 7L: Climb heading 078° to 1550, then climbing left turn heading 075°, at 4 DME east of PXR VORTAC, climbing right turn heading 100°. Expect RADAR vectors to BXX VORTAC. Thence . . . .

TAKEOFF RUNWAY 7R: Climb heading 078° to 1550, then climbing left turn heading 070°, at 4 DME east of PXR VORTAC, climbing right turn heading 100°. Expect RADAR vectors to BXX VORTAC. Thence . . . .

TAKEOFF RUNWAY 25L: Climb heading 258° to 1550, then climbing left turn heading 240°, at 13 DME west of PXR VORTAC, climbing right turn heading 280° to the BXX R-077 to BXX VORTAC. Thence . . . .

TAKEOFF RUNWAY 25R: Climb heading 258° to 1550, then climbing left turn heading 240°, at 13 DME west of PXR VORTAC, climbing right turn heading 280° to the BXX R-077 to BXX VORTAC. Thence . . . .

TAKEOFF RUNWAY 26: Climb heading 258° to 1550, then climbing left turn heading 240°, at 13 DME west of PXR VORTAC, climbing right turn heading 280° to the BXX R-077 to BXX VORTAC. Thence . . . .

. . . . maintain 8000, thence via (transition). Expect filed altitude 3 minutes after departure.

LOST COMMUNICATIONS: Expect filed altitude 3 minutes after departure.

BLYTHE TRANSITION (BXX4.BLH): From over BXX VORTAC via BXX R-262 and BLH R-080 to BLH VORTAC.

PALMDALE TRANSITION (BXX4.PMD): From over BXX VORTAC via BXX R-269 to CURIV INT, then via PSP R-080 to DECAS INT, then via BLH R-278 and PMD R-095 to PMD VORTAC.

PALM SPRINGS TRANSITION (BXX4.PSP): From over BXX VORTAC via BXX R-269 to CURIV INT, then via PSP R-080 to PSP VORTAC.

PARKER TRANSITION (BXX4.PKE): From over BXX VORTAC via BXX R-279 and PKE R-097 to PKE VORTAC.

SW-4, 20 FEB 2025 to 20 MAR 2025

SW-4, 20 FEB 2025 to 20 MAR 2025