

APP CRS	Rwy Idg	4538
159°	TDZE	344
	Apt Elev	345

RNAV (GPS) RWY 14

FITCHBURG MUNI (FIT)

RNP APCH.	MISSED APPROACH: Climbing left turn to 3500 direct DALIA and hold.
<p>▼ Rwy 14 helicopter visibility reduction below ¾ SM NA.</p> <p>▲ Circling NA southwest of Rwy 14-32 at night.</p> <p>❄ -22°C</p>	

ASOS 135.175	BOSTON APP CON 124.4 279.6	UNICOM 122.7 (CTAF)	123.0 0
------------------------	--------------------------------------	-------------------------------	-----------------------

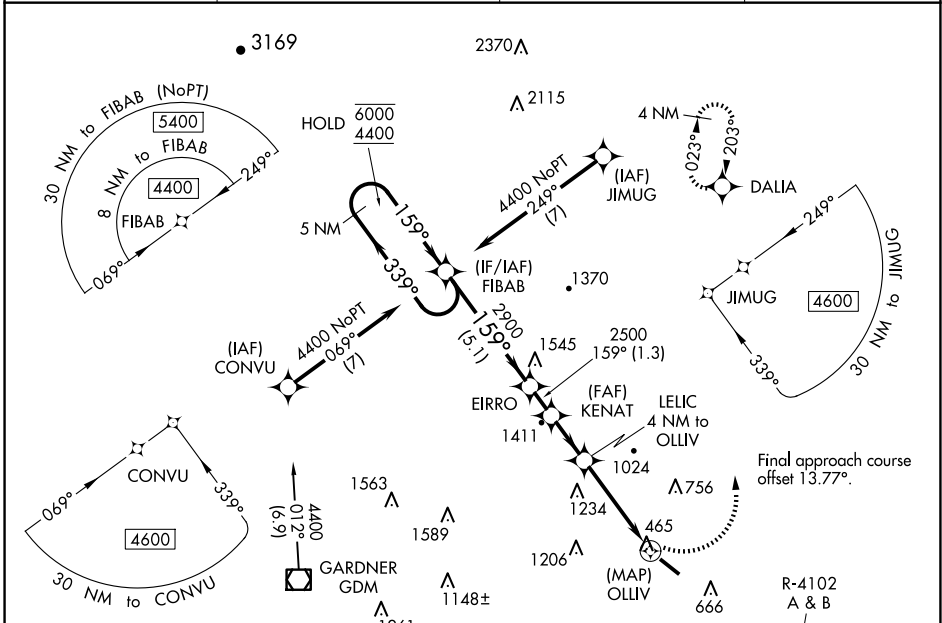

NE-1, 20 FEB 2025 to 20 MAR 2025

NE-1, 20 FEB 2025 to 20 MAR 2025

ELEV 345	D	TDZE 344
----------	----------	----------

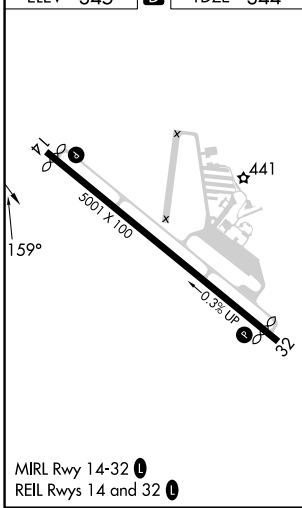

Procedure NA for arrival on GDM VOR/DME airway radials 339 CW 042.

5 NM Holding Pattern	FIBAB	Visual Segment - Obstacles.	3500	DALIA
6000 ← 339°	4400 → 159°	2900	2500	1860
		5.1 NM	1.3 NM	2 NM
		1.3 NM	2.7 NM	0.5 NM
CATEGORY	A	B	C	D
LNAV MDA	1420-1¼ 1076 (1100-1¼)	1420-1½ 1076 (1100-1½)	1420-3 1076 (1100-3)	NA
C CIRCLING	1420-1¼ 1075 (1100-1¼)	1420-1½ 1075 (1100-1½)	1520-3 1175 (1200-3)	NA