

WAAS CH <b>70615</b> <b>W27A</b>	APP CRS <b>275°</b>	Rwy Idg TDZE Apt Elev	<b>6520</b> <b>974</b> <b>981</b>
--	------------------------	-----------------------------	---

# RNAV (GPS) RWY 27L

OAKLAND COUNTY INTL (PTK)

RNP APCH.

▼ For uncompensated Baro-VNAV systems, LNAV/VNAV NA below -16°C (4°F) or above 47°C (116°F).  
 ▲ Baro-VNAV and VDP NA when using Coleman A Young altimeter setting. Circling Rwy 9L, 36 NA at night. When local altimeter setting not received, use Coleman A Young Muni altimeter setting and increase LPV DA to 1279 feet, LNAV/VNAV DA to 1568 and all MDA 120 feet, increase LPV and LNAV/VNAV all cats visibility ½ SM, LNAV Cat C/D, and Circling Cat C/D visibility ½ SM.

MISSED APPROACH:  
Climb to 3000 direct  
EDESE and hold.

ATIS <b>125.025</b>	DETROIT APP CON <b>132.35 284.0</b>	PONTIAC TOWER * <b>120.5 (CTAF) 0</b>	GND CON <b>121.9</b>	CLNC DEL <b>118.25</b>	UNICOM <b>122.95</b>
------------------------	--	--	-------------------------	---------------------------	-------------------------

Procedure NA for arrivals on FNT VORTAC  
airway radials 076 CW 097.

FLINT  
FNT

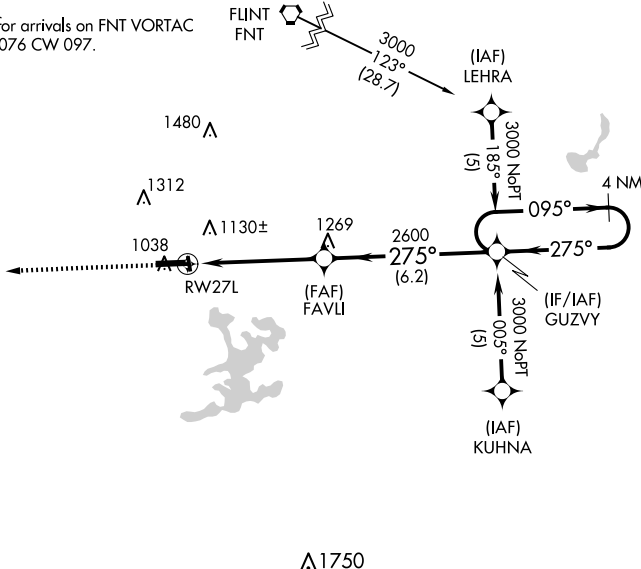
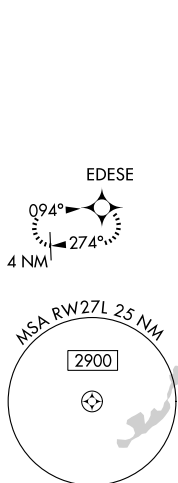

ELEV 981	<b>D</b>	TDZE 974
----------	----------	----------

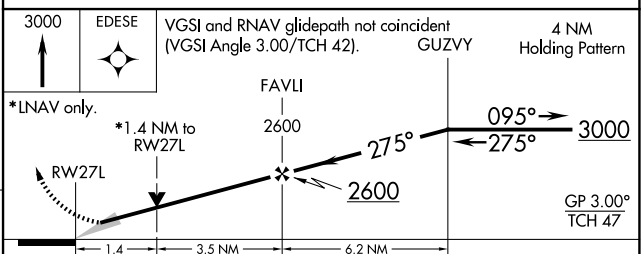
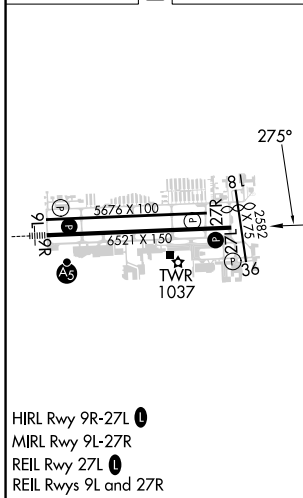

CATEGORY	A	B	C	D
LPV DA	1174-3/4 200 (200-3/4)			
LNAV/VNAV DA	1463-1 3/4 489 (500-1 3/4)			
LNAV MDA	1460-1	486 (500-1)	1460-1 1/4 486 (500-1 1/4)	1460-1 1/2 486 (500-1 1/2)
<b>C</b> CIRCLING	1500-1 519 (600-1)	1540-1 559 (600-1)	1640-1 3/4 659 (700-1 3/4)	1640-2 659 (700-2)

EC-1, 20 FEB 2025 to 20 MAR 2025

EC-1, 20 FEB 2025 to 20 MAR 2025