

LOC I-HIB 108.75	APP CRS 310°	Rwy Idg TDZE Apt Elev	6758 1345 1354
----------------------------	------------------------	-----------------------------	---

ILS or LOC RWY 31

RANGE RGNL (HIB)

⚠ VDP NA when using Eveleth altimeter setting. Caution opposing ILS continuously on. When local altimeter setting not received, use Eveleth altimeter setting and increase S-ILS 31 DA to 1581 feet; increase all MDAs 40 feet and increase S-LOC 31 Cat C/D visibility 1/2 SM and Circling Cat C 1/4 SM. Increase BOYAC fix minimums S-LOC 31 Cat C/D visibility 1/2 SM and Circling Cat C 1/4 SM. #DME from HIB VOR/DME. DME use requires simultaneous reception of I-HIB and HIB DME. *1780 when using Eveleth altimeter setting, increase BOYAC fix minimums S-LOC 31 Cat C/D visibility to 1 SM.

MALSR

MISSED APPROACH: Climb to 2500 then climbing right turn to 3600 direct HIB VOR/DME and hold.

ASOS 126.425	DULUTH APP CON 125.45 233.7	CINC DEL 127.4	UNICOM 123.0 (CTAF) 
------------------------	---------------------------------------	--------------------------	---

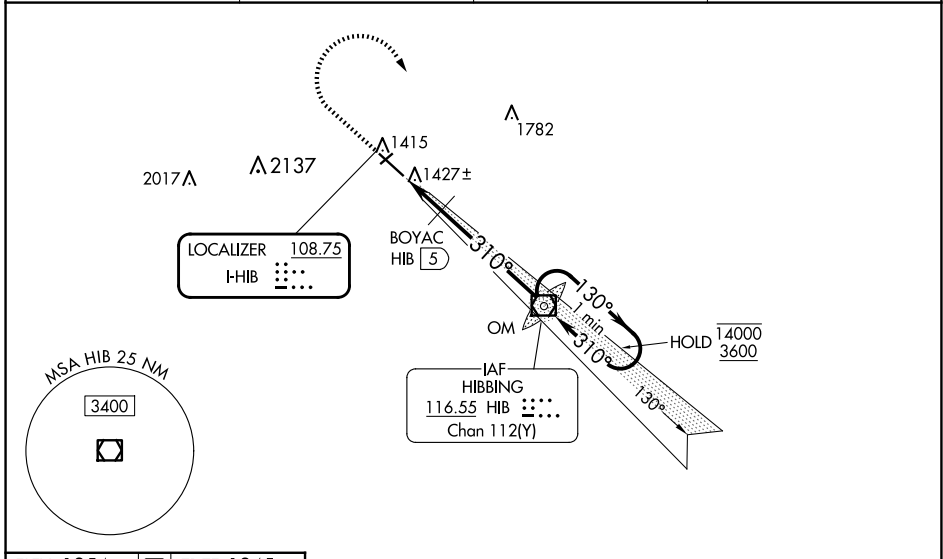

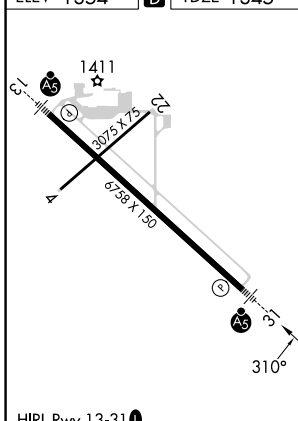
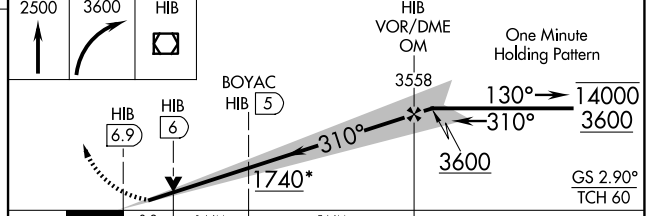
ELEV 1354	D	TDZE 1345	2500	3600	HIB	HIB VOR/DME OM	One Minute Holding Pattern
							
CATEGORY	A		B		C		D
S-ILS 31	1545-1/2		200 (200-1/2)				
S-LOC 31	1740-1/2		395 (400-1/2)		1740-5/8		395 (400-5/8)
CIRCLING	1900-1		546 (600-1)		1920-1 1/2		1980-2
# BOYAC FIX MINIMUMS							
S-LOC 31	1680-1/2		335 (400-1/2)				
CIRCLING	1900-1		546 (600-1)		1920-1 1/2		1980-2
GS 2.90° TCH 60							

NC-1, 20 FEB 2025 to 20 MAR 2025

NC-1, 20 FEB 2025 to 20 MAR 2025