

WAAS CH <b>56232</b> <b>W16A</b>	APP CRS <b>165°</b>	Rwy Idg TDZE <b>622</b> Apt Elev <b>630</b>	<b>4398</b>
--	------------------------	---	-------------

# RNAV (GPS) RWY 16

GREATER KANKAKEE (IKK)

RNP APCH.	MISSED APPROACH: Climb to 2300 direct JETIB and hold.
<p>▼ Rwy 16 helicopter visibility reduction below 1 SM NA. Straight-in and Circling Rwy 16 NA at night, Circling Rwy 34 NA at night.</p>	

AWOS-3 <b>128.475</b>	CHICAGO CENTER <b>132.5 284.7</b>	UNICOM <b>123.0 (CTAF) 0</b>
--------------------------	--------------------------------------	---------------------------------

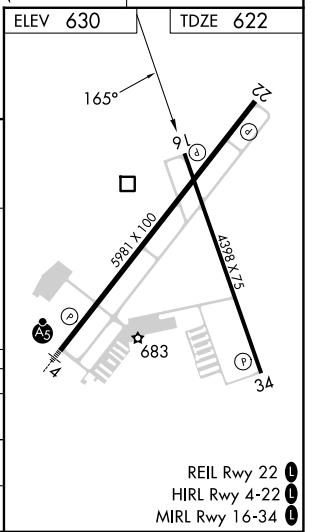
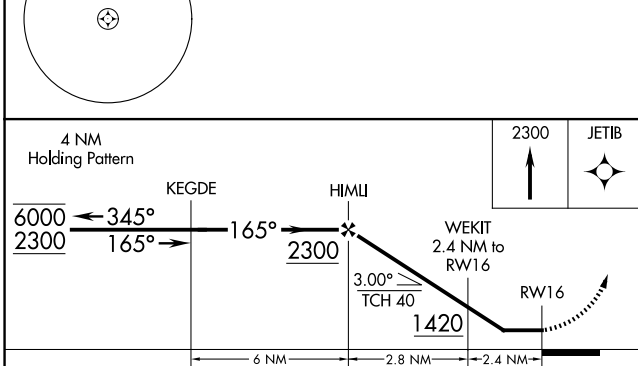
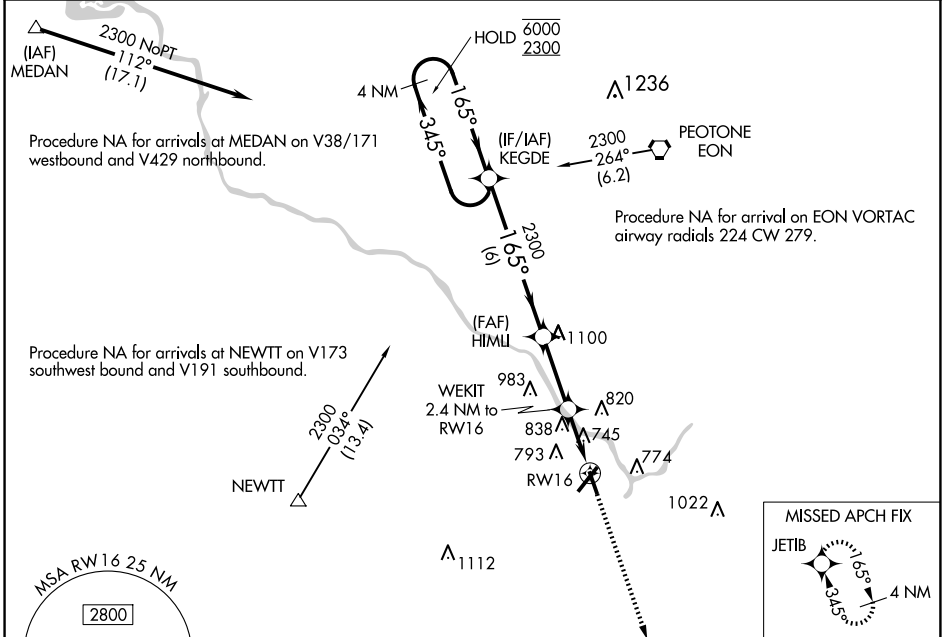

CATEGORY	A	B	C	D
LP MDA	1060-1	438 (500-1)	1060-1¼	438 (400-1¼)
LNAV MDA	1100-1	478 (500-1)	1100-1¾	478 (500-1¾)
<b>C</b> CIRCLING	1100-1	470 (500-1)	1140-1½ 510 (600-1½)	1340-2¼ 710 (800-2¼)

EC-3, 20 FEB 2025 to 20 MAR 2025

EC-3, 20 FEB 2025 to 20 MAR 2025