

| | | | |
|--|------------------------|-----------------------------|---|
| WAAS CH 50209 W11A | APP CRS 109° | Rwy Idg TDZE Apt Elev | 4300 736 737 |
|--|------------------------|-----------------------------|---|

RNAV (GPS) RWY 11

OWOSSO COMMUNITY (RNP)

RNP APCH.

▼ Circling NA to Rws 6, 18, 24, and 36. For uncompensated Baro-VNAV systems, LNAV/VNAV NA below -16°C (4°F) or above 54°C (130°F). Rwy 11 helicopter visibility reduction below ¾ SM NA.

MISSED APPROACH: Climb to 3000 direct FIKTA and on track 057° to CLIOO and hold.

| | | |
|--------------------------|--|---------------------------------|
| AWOS-3 118.025 | GREAT LAKES APP CON * 128.55 257.9 | UNICOM 123.0 (CTAF) 0 |
|--------------------------|--|---------------------------------|

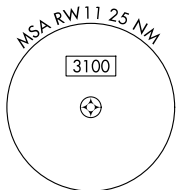
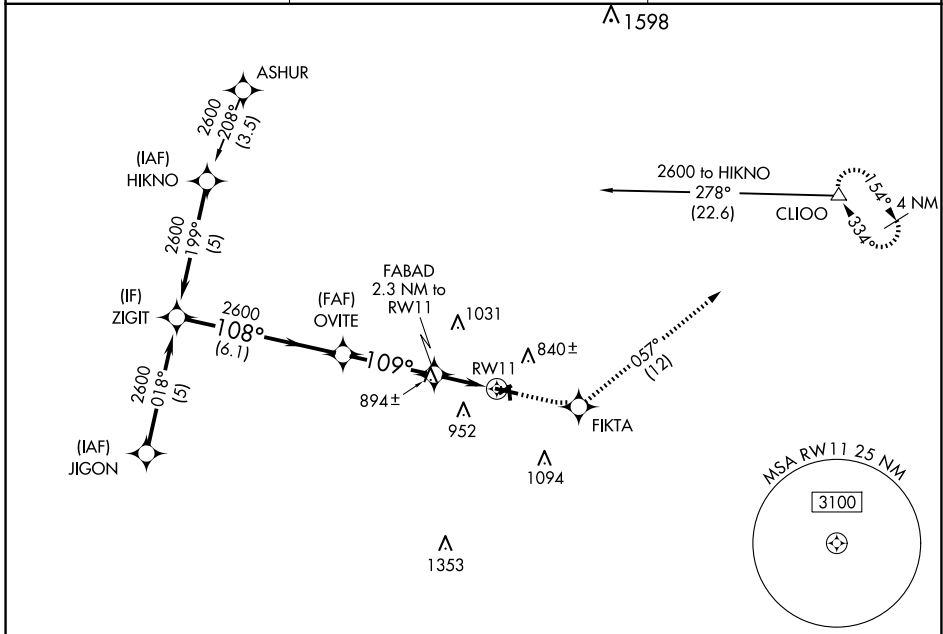

EC-1, 20 FEB 2025 to 20 MAR 2025

EC-1, 20 FEB 2025 to 20 MAR 2025

| | |
|----------|----------|
| ELEV 737 | TDZE 736 |
|----------|----------|

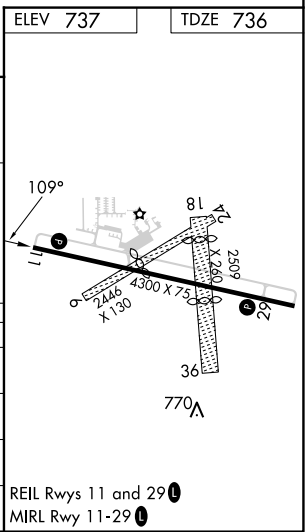
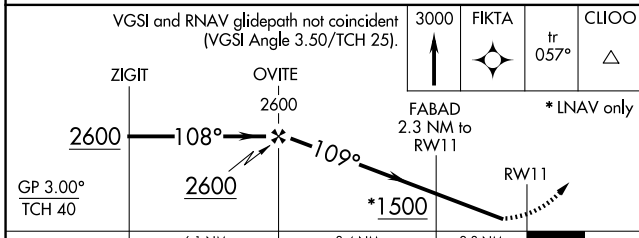

| CATEGORY | A | B | C | D |
|-------------------|-----------------------|-----------------------|-------------------------|----|
| LPV DA | 1079-1¼ | 343 (400-1¼) | | NA |
| LNAV/VNAV DA | 1258-2 | 522 (600-2) | | NA |
| LNAV MDA | 1180-1 | 444 (500-1) | 1180-1¼ 444 (500-1¼) | NA |
| C CIRCLING | 1220-1 483 (500-1) | 1260-1 523 (600-1) | 1400-1¾ 663 (700-1¾) | NA |

REIL Rws 11 and 29
MIRL Rwy 11-29