

VORTAC FNT 116.9 Chan 116	APP CRS 281°	Rwy ldg 4300 TDZE 736 Apt Elev 736
---	------------------------	---

VOR/DME RWY 29

OWOSSO COMMUNITY (RNP)

▼ Circling NA to Rwy 6, 18, 24 and 36. Rwy 29 helicopter visibility reduction below ¼ SM NA. When local altimeter setting not received, use Flint altimeter setting and increase all MDA 60 feet and S-29 Cat C visibility ¼ mile.

MISSED APPROACH: Climb to 1900 then climbing right turn to 2700 via FNT VORTAC R-286 to OWOSSO INT and hold.

AWOS-3 118.025	GREAT LAKES APP CON ★ 128.55 257.9	UNICOM 123.0 (CTAF) 0
--------------------------	--	---------------------------------

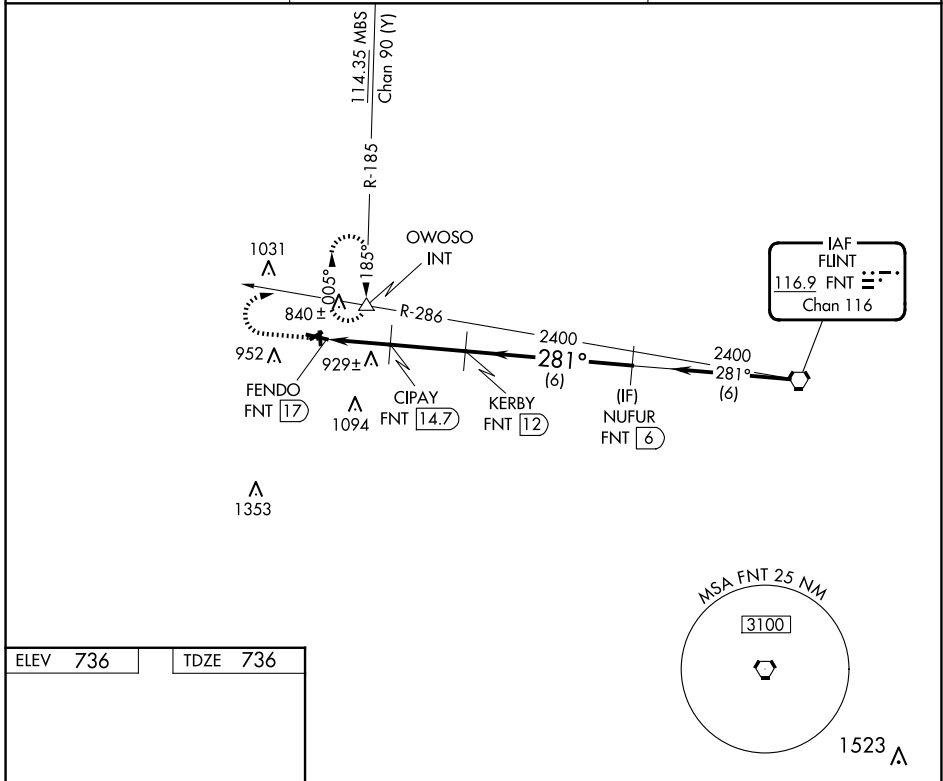

ELEV 736	TDZE 736
----------	----------

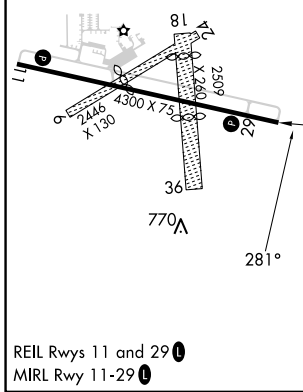

1900	2700	OWOSSO	VGSI and descent angles not coincident (VGSI Angle 4.00/TCH 20).	NUFUR FNT (6)
↑	FNT R-286	△		
		KERBY FNT (12)		
		CIPAY FNT (14.7)		
		FENDO FNT (17)		
			2400	Procedure Turn NA
			281°	
			2400	
			1500	
			3.07°	
			TCH 40	
			2.3 NM	
			2.7 NM	
			6 NM	
CATEGORY	A	B	C	D
S-29	1180-1	444 (500-1)	1180-1¼ 444 (500-1¼)	NA
CIRCLING	1220-1 483 (500-1)	1260-1 523 (600-1)	1400-1¾ 663 (700-1¾)	NA

EC-1, 20 FEB 2025 to 20 MAR 2025

EC-1, 20 FEB 2025 to 20 MAR 2025