

|             |          |             |
|-------------|----------|-------------|
| APP CRS     | Rwy Idg  | <b>3214</b> |
| <b>121°</b> | TDZE     | <b>64</b>   |
|             | Apt Elev | <b>64</b>   |

# RNAV (GPS) RWY 12

GOODEN AIRPARK (RJD)

|                 |   |   |
|-----------------|---|---|
| RNP APCH - GPS. | Procedure NA at night. Use Easton altimeter setting: when not received, procedure NA. Rwy 12 helicopter visibility reduction below 1 SM NA. | MISSED APPROACH: Climb to 2000 direct PEKME and hold. |
|-----------------|---|---|

|                                |  |                                 |
|--------------------------------|--|---------------------------------|
| ESN AWOS-3PT<br><b>124.475</b> | POTOMAC APP CON<br><b>124.55 317.425</b> | UNICOM<br><b>122.8 (CTAF) 0</b> |
|--------------------------------|--|---------------------------------|

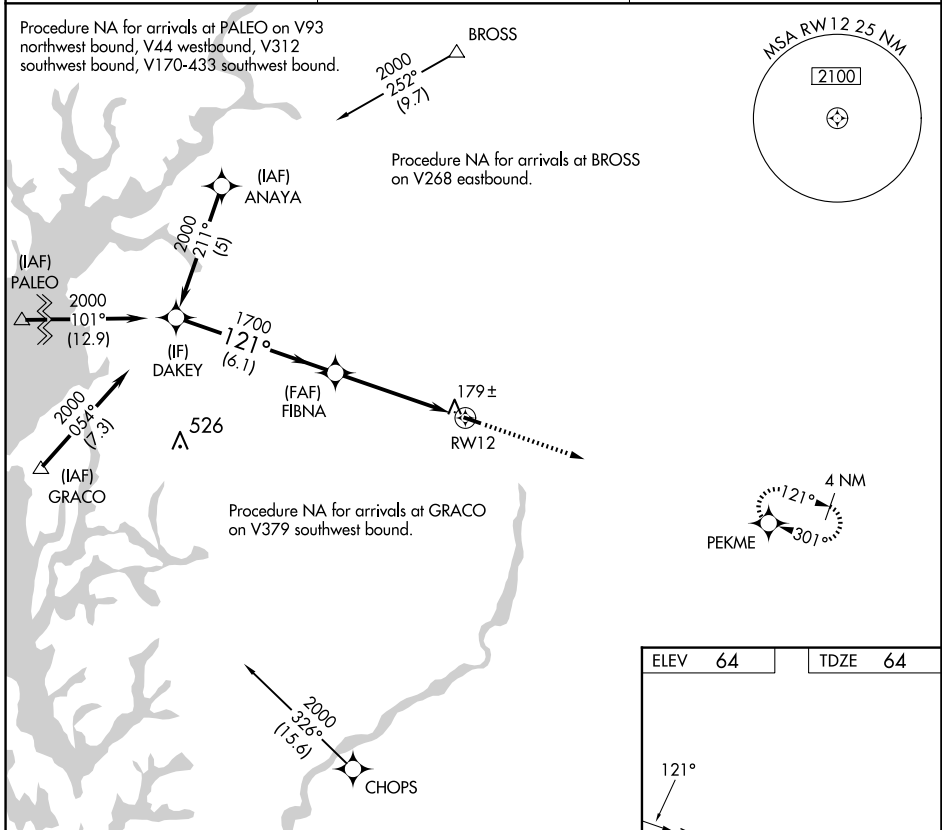

NE-3, 20 FEB 2025 to 20 MAR 2025

NE-3, 20 FEB 2025 to 20 MAR 2025

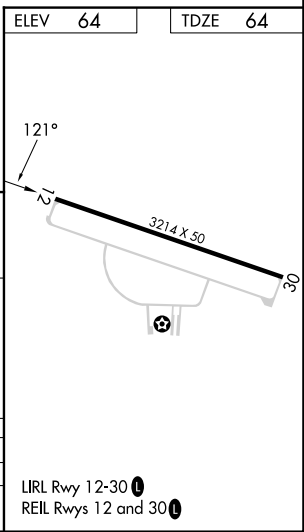
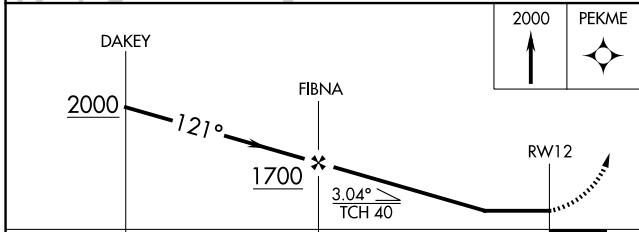

|          |       |             |   |    |
|----------|-------|-------------|---|----|
| CATEGORY | A     | B           | C | D  |
| LNAV MDA | 480-1 | 416 (500-1) |   | NA |
| CIRCLING | 520-1 | 456 (500-1) |   | NA |