

WAAS CH 86637 W27A	APP CRS 269°	Rwy Idg TDZE Apt Elev	3098 465 465
--	------------------------	-----------------------------	---

RNAV (GPS) RWY 27

BRANDYWINE RGNL (OQN)

RNP APCH - GPS.		MISSED APPROACH: Climb to 1500 then climbing right turn to 2900 direct GONVE and hold.	
<p>⚠ Rwy 27 helicopter visibility reduction below 3/4 SM NA. When local altimeter setting not received, use Coatesville altimeter setting and increase all MDAs 60 feet.</p>			

AWOS-3T 121.4	PHILADELPHIA APP CON 124.35 319.15	CLNC DEL 125.6	UNICOM 123.075 (CTAF)
-------------------------	--	--------------------------	---------------------------------

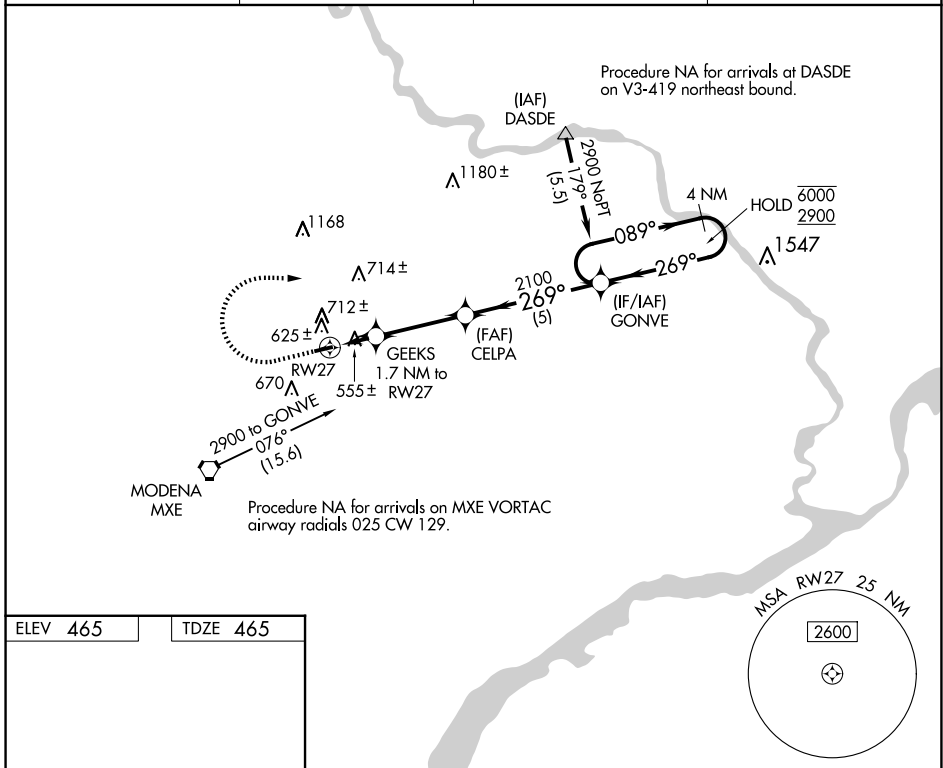

NE-4, 20 MAR 2025 to 17 APR 2025

NE-4, 20 MAR 2025 to 17 APR 2025

ELEV 465	TDZE 465
-----------------	-----------------

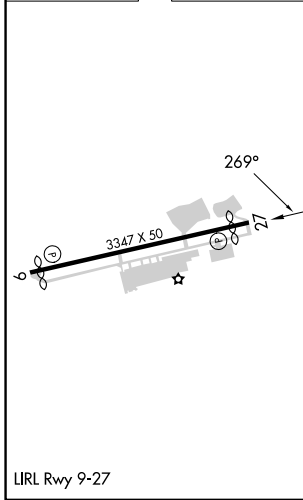

1500	2900	GONVE	VGSI and descent angles not coincident (VGSI Angle 3.00/TCH 20).	
		GONVE	4 NM Holding Pattern	
CATEGORY	A	B	C	D
LP MDA	820-1	355 (400-1)		NA
LNAV MDA	860-1	395 (400-1)		NA
<input checked="" type="checkbox"/> CIRCLING	1080-1	615 (700-1)		NA