

APP CRS	Rwy Ldg	4500
060°	TDZE	29
	Apt Elev	29

RNAV (GPS) RWY 6

POINT LAY LRRS (PIZ)(PPIZ)

RNP APCH - GPS.
 ☁ -33°C When local altimeter setting not received, procedure NA.

MISSED APPROACH: Climb to 2400 direct WUMLU and hold.

AWOS-3P 135.65	ANCHORAGE CENTER 119.65 363.25	BARROW RADIO 122.4	CTAF 122.8
--------------------------	--	------------------------------	----------------------

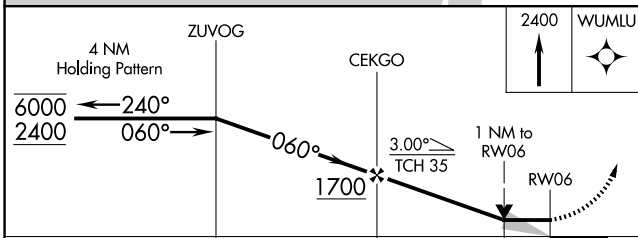
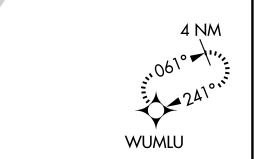
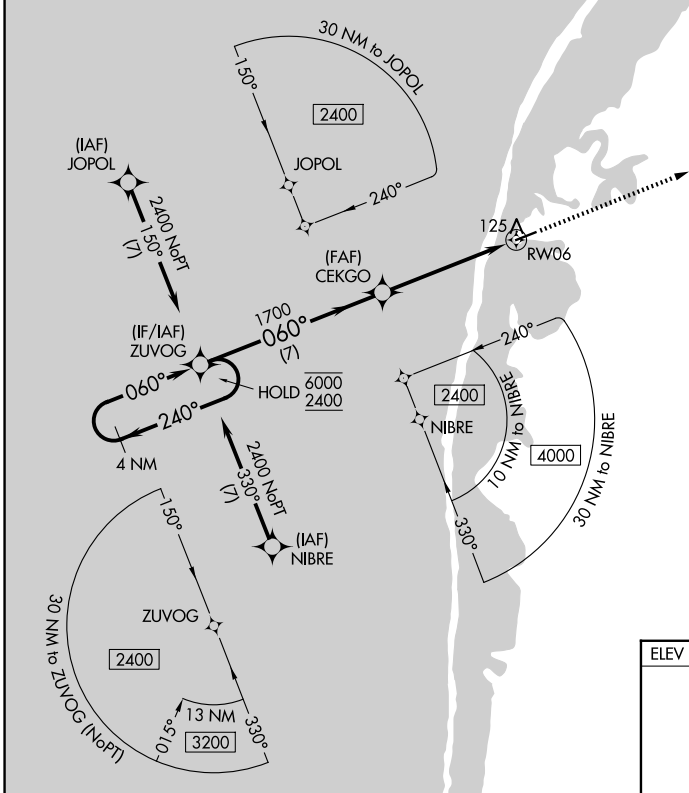

ELEV 29	TDZE 29
---------	---------

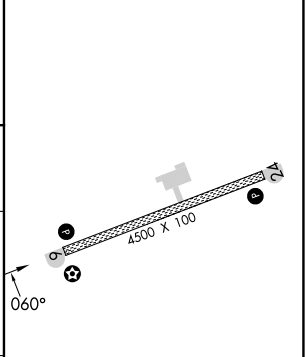

CATEGORY	A	B	C	D
LNVA MDA	380-1 351 (400-1)			NA
CIRCLING	440-1 411 (500-1)	480-1 451 (500-1)	480-1½ 451 (500-1½)	NA

MIRL Rwy 6-24
 REIL Rws 6 and 24

AK, 19 MAR 2026 to 14 MAY 2026

AK, 19 MAR 2026 to 14 MAY 2026