

LOC I-PKX 108.3	APP CRS 356°	Rwy Ldg TDZE Apt Elev	4097 1086 1096
---------------------------	------------------------	-----------------------------	---

LOC RWY 36
JOHNSON COUNTY EXEC (OJC)

NA Helicopter visibility reduction below 3/4 SM not authorized. For inoperative MALSRS, increase S-36 Cats A and B visibility 1/4 mile.	MALSRS 	MISSED APPROACH: Climb to 1700 then climbing right turn to 2700 direct HERBB LOM and hold.	

ATIS 119.35	KANSAS CITY APP CON 118.9 251.075	EXECUTIVE TOWER* 126.0 (CTAF) 225.4	GND CON 121.6	UNICOM 122.95
-----------------------	---	---	-------------------------	-------------------------

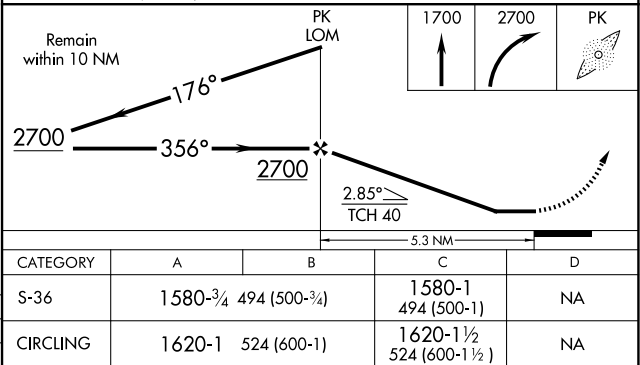
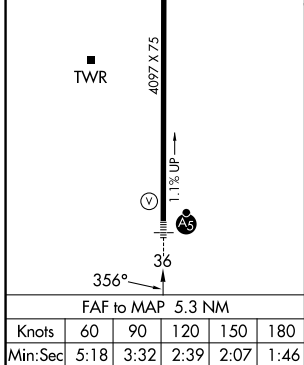
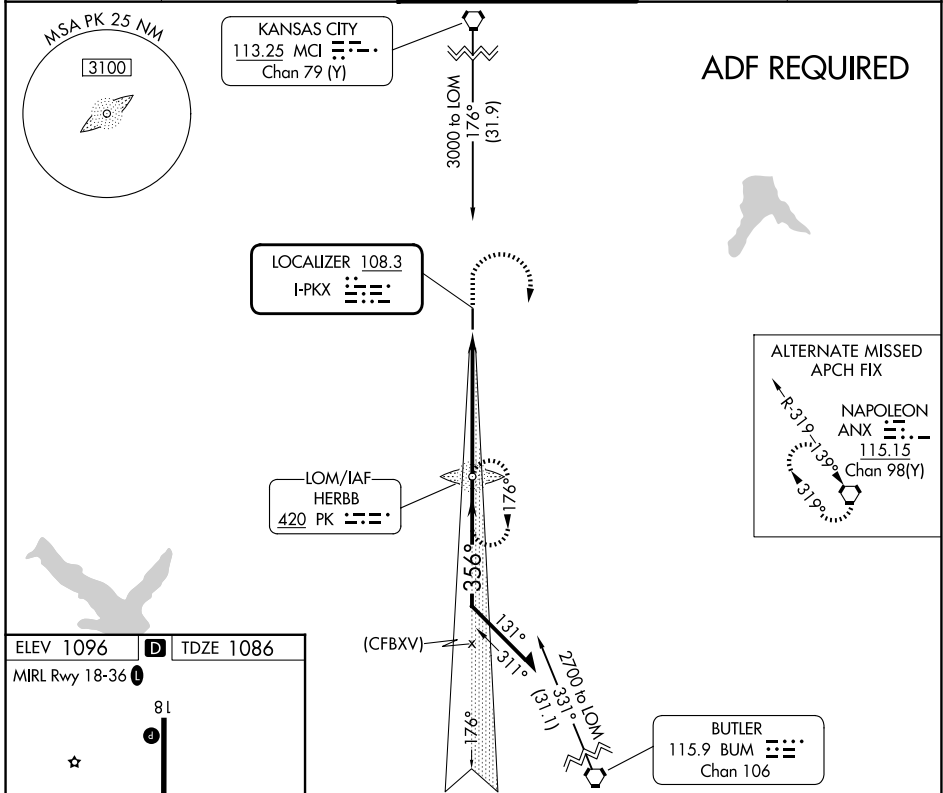

NC-2, 19 MAR 2026 to 16 APR 2026

NC-2, 19 MAR 2026 to 16 APR 2026