

BENKY SIX ARRIVAL (RNAV) Transition Routes
(BENKY.BENKY6) 05NOV20

CHICAGO APP CON
119.0 292.125
D-ATIS
135.4 282.225

- NOTE: RADAR required.
- NOTE: RNAV 1.
- NOTE: DME/DME/IRU or GPS required.
- NOTE: CASHN TRANSITION: ATC assigned only.
- NOTE: DRAMS TRANSITION: ATC assigned only.

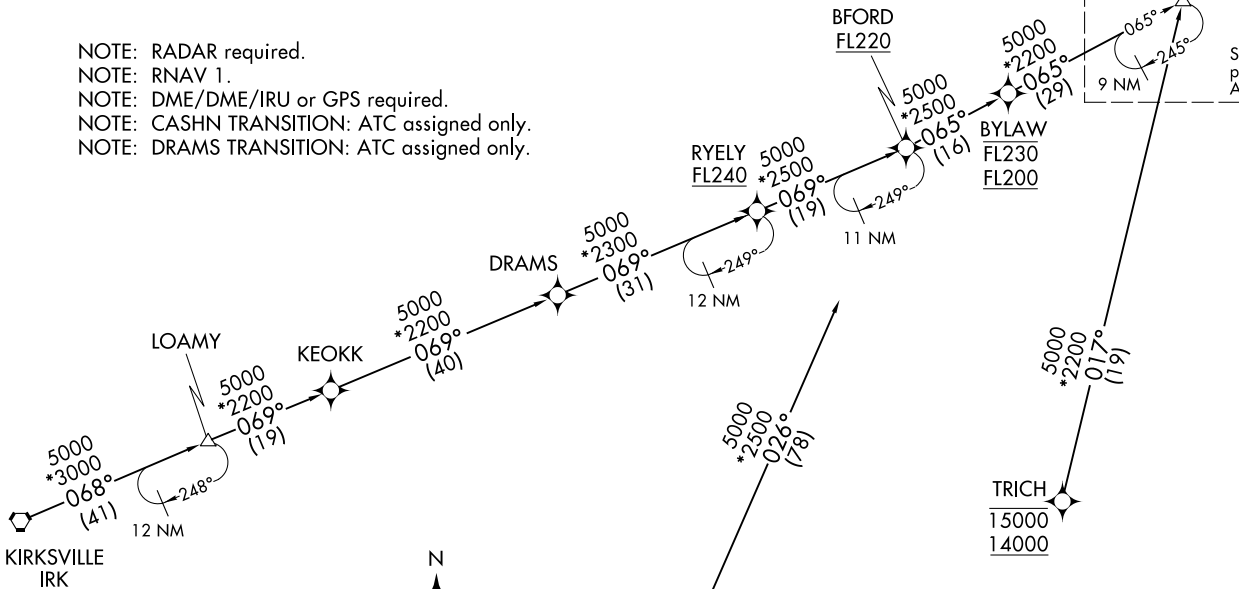

See following page for Arrival Route.

- BFORD TRANSITION (BFORD.BENKY6):
- BYLAW TRANSITION (BYLAW.BENKY6):
- CASHN TRANSITION (CASHN.BENKY6):
- DRAMS TRANSITION (DRAMS.BENKY6):
- KIRKSVILLE TRANSITION (IRK.BENKY6):
- LOAMY TRANSITION (LOAMY.BENKY6):
- TRICH TRANSITION (TRICH.BENKY6):

(CONTINUED ON FOLLOWING PAGE)

NOTE: Chart not to scale.

(BENKY.BENKY6) 25219
AL-166 (FAA)
CHICAGO O'HARE INTL (ORD)
CHICAGO, ILLINOIS

BENKY SIX ARRIVAL (RNAV) Arrival Routes
 (BENKY.BENKY6) 05NOV20

(BENKY.BENKY6) 20310
 Arrival Routes
 AL-166 (FAA)

CHICAGO APP CON
 119.0 292.125
 D-ATIS
 135.4 282.225

NOTE: RADAR required.
 NOTE: RNAV 1.
 NOTE: DME/DME/IRU or GPS required.
 NOTE: ORD LANDING EAST: Expect RADAR vectors to final approach course after AHSTN.

BENKY
 12000

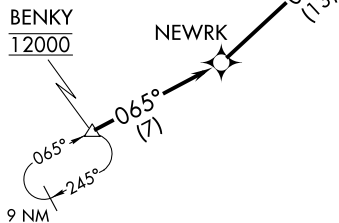

NOTE: Chart not to scale.

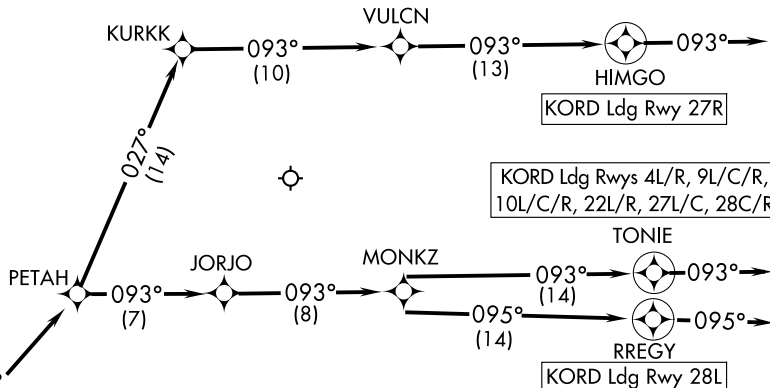

ARRIVAL ROUTE DESCRIPTION

From BENKY on track 065° to NEWRK, then on track 051° to AHSTN, then on track 045° to PETAH.

LANDING RWYS 4L/R, 9L/C/R, 10L/C/R, 22L/R, 27L/C, 28C/R:
 From PETAH on track 093° to JORJO, then on track 093° to MONKZ, then on track 093° to TONIE, then on track 093°. Expect RADAR vectors to final approach course.

LANDING RWY 27R: From PETAH on track 027° to KURKK, then on track 093° to VULCN, then on track 093° to HIMGO, then on track 093°. Expect RADAR vectors to final approach course.

LANDING RWY 28L: From PETAH on track 093° to JORJO, then on track 093° to MONKZ, then on track 095° to RREGY, then on track 095°. Expect RADAR vectors to final approach course.

CHICAGO O'HARE INTL (ORD)
 CHICAGO, ILLINOIS