

WAAS CH 66012 W18A	APP CRS 185°	Rwy Ldg 12004 TDZE 96 Apt Elev 96
--	------------------------	--

RNAV (GPS) RWY 18L

ORLANDO INTL (MCO)

For uncompensated Baro-VNAV systems, LNAV/VNAV NA below -1°C (31°F) or above 54°C (130°F). DME/DME RNP-0.3 NA. Simultaneous approach authorized with Rwy 17L/R. LNAV procedure NA during simultaneous operations. Use of FD or AP providing RNAV track guidance required during simultaneous operations.

MISSED APPROACH: Climb to 500 then climbing right turn to 4000 direct CAMBE and hold, continue climb-in-hold to 4000.

D-ATIS 121.25	ORLANDO APP CON 124.8 307.0	ORLANDO TOWER 118.45 253.5 (17L/35R, 17R/35L) 124.3 253.5 (18L/36R, 18R/36L)	GND CON 126.4 (E) 121.8 (W)
-------------------------	---------------------------------------	--	---

RADAR REQUIRED

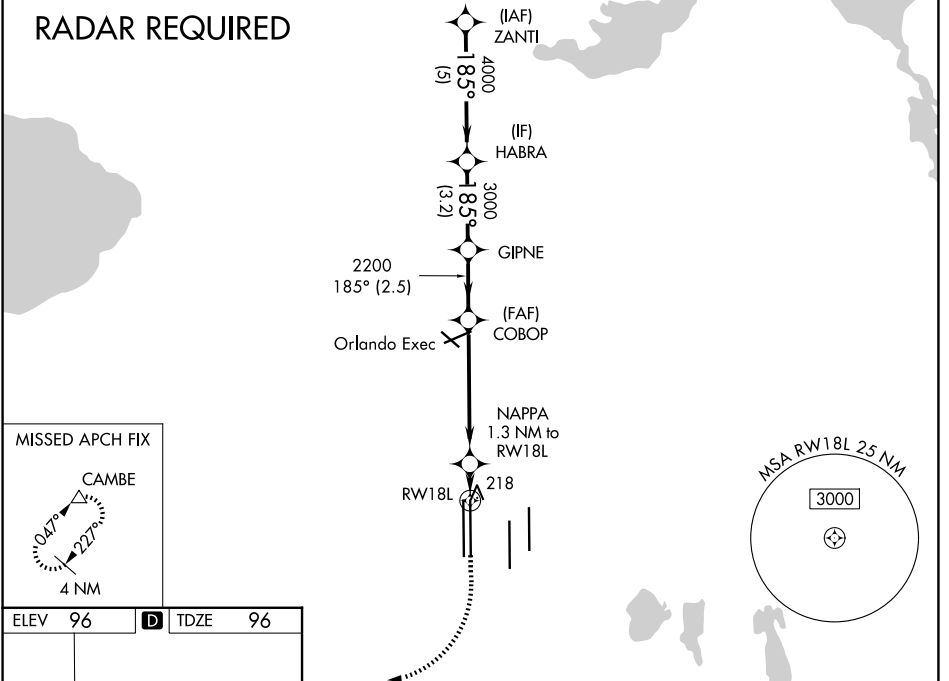

SE-3, 16 APR 2026 to 14 MAY 2026

SE-3, 16 APR 2026 to 14 MAY 2026

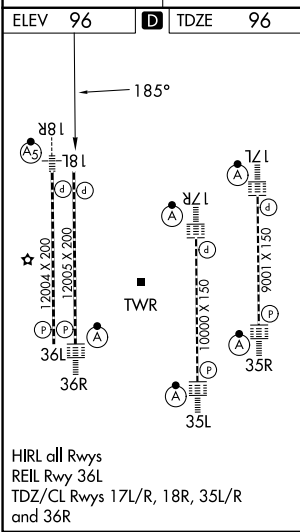

VGSI and RNAV glidepath not coincident (VGSI Angle 3.00/TCH 71).

4000	4000	3000	2200	2200	218
ZANTI	HABRA	GIPNE	COBOP	NAPPA	RWY 18L
5 NM	3.2 NM	2.5 NM	5.2 NM	1.3 NM	
GP 3.00°	TCH 55			*560	
500	4000	CAMBE			
CATEGORY	A	B	C	D	
LPV DA		296/40	200 (200-¾)		
LNAV/VNAV DA		398/50	302 (400-1)		
LNAV MDA	480/55	384 (400-1)	480/60	384 (400-1¼)	
CIRCLING	740-1	644 (700-1)	740-1¾ 644 (700-1¾)	740-2 644 (700-2)	

*LNAV only.