

LOC/DME I-AUO 110.1 Chan 38	APP CRS 005°	Rwy Ldg TDZE Apt Elev	5264 759 777
---	------------------------	-----------------------------	---

ILS or LOC RWY 36

AUBURN UNIVERSITY RGNL (AUO)

DME required.	MALSF	MISSED APPROACH: Climb to 1500 then climbing right turn to 3000 on heading 175° and on LGC VORTAC R-196 to HESEL/I-AUO 13.8 DME/RADAR and hold.
---------------	-------	---

AWOS-3PT 132.575	ATLANTA APP CON * 125.5 323.1	AUBURN TOWER * 123.875 (CTAF) 0	GND CON * 121.625	UNICOM 123.0
----------------------------	---	--	-----------------------------	------------------------

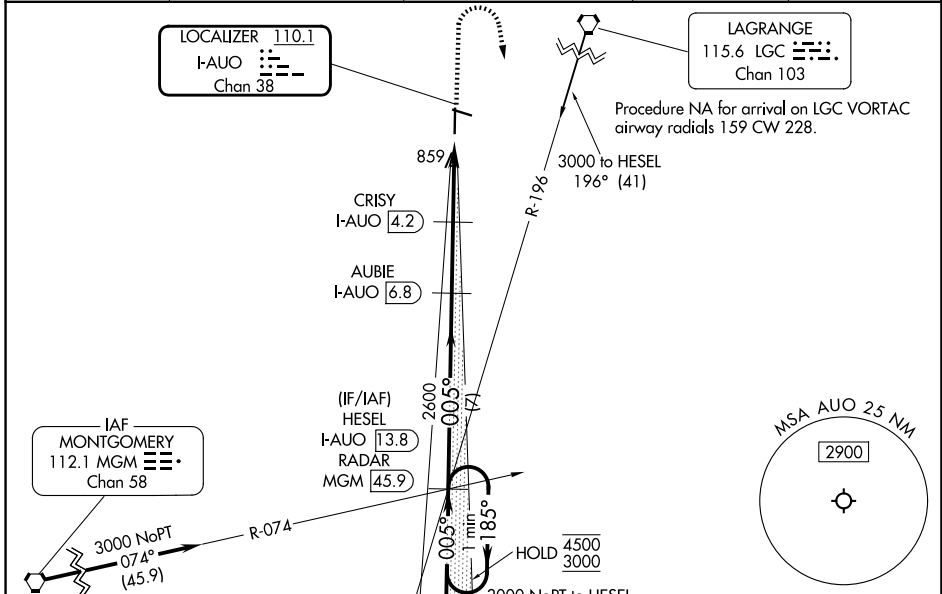

ELEV 777	TDZE 759
----------	----------

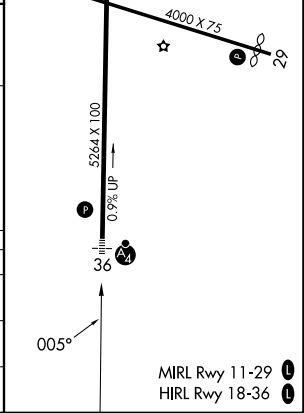
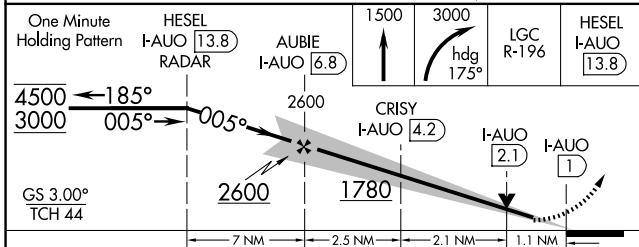

CATEGORY	A	B	C	D
S-ILS 36		959- ³ / ₄	200 (200- ³ / ₄)	
S-LOC 36		1120- ³ / ₄	361 (400- ³ / ₄)	
CIRCLING	1280-1 503 (600-1)	1360-1 583 (600-1)	1380-1 ³ / ₄ 603 (700-1 ³ / ₄)	1440-2 663 (700-2)

SE-4, 16 APR 2026 to 14 MAY 2026

SE-4, 16 APR 2026 to 14 MAY 2026