

WAAS CH 56232 W16A	APP CRS 165°	Rwy Ldg TDZE Apt Elev	4398 622 630
--	------------------------	-----------------------------	---

RNAV (GPS) RWY 16

GREATER KANKAKEE (IKK)

RNP APCH.	MISSED APPROACH: Climb to 2300 direct JETIB and hold.
<p>▼ Rwy 16 helicopter visibility reduction below 1 SM NA. Straight-in and Circling Rwy 16 NA at night, Circling Rwy 34 NA at night.</p>	

AWOS-3 128.475	CHICAGO CENTER 132.5 284.7	UNICOM 123.0 (CTAF) 0
--------------------------	--------------------------------------	---------------------------------

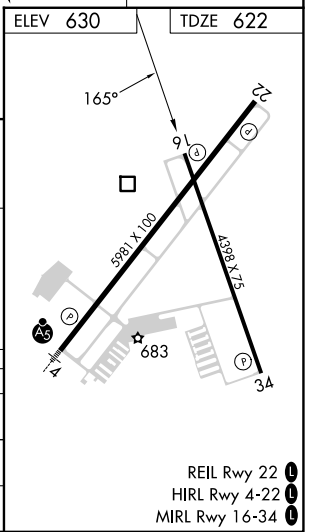
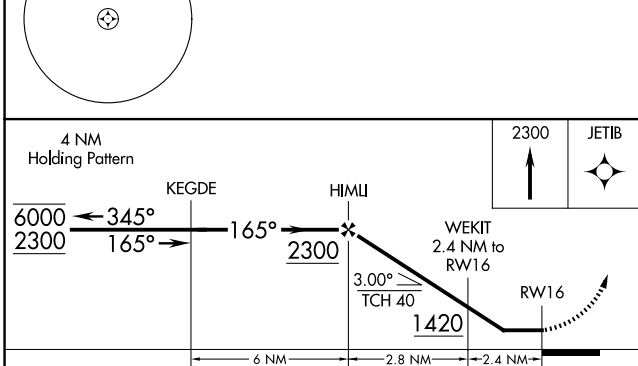
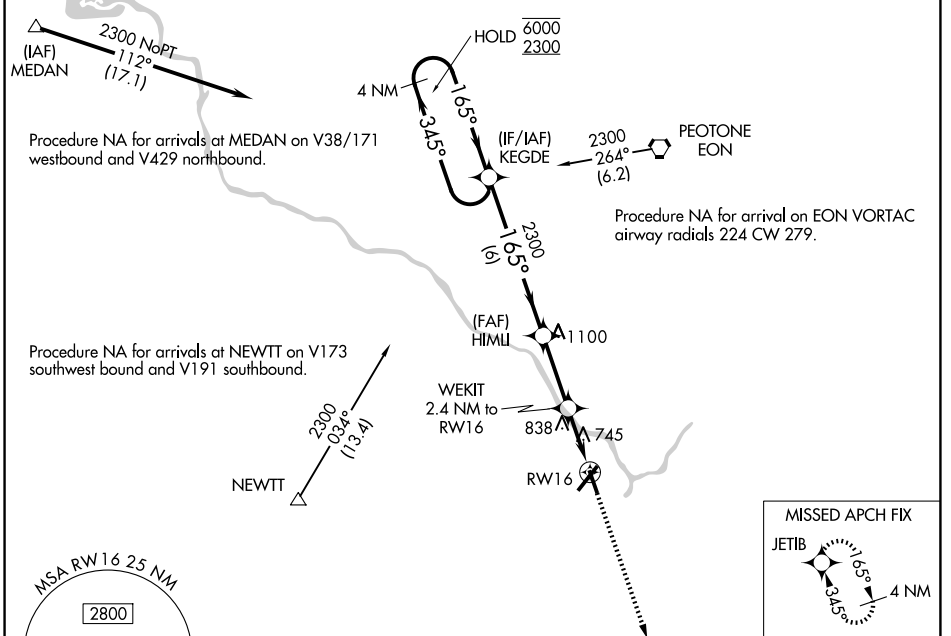

CATEGORY	A	B	C	D
LP MDA	1060-1	438 (500-1)	1060-1¼	438 (400-1¼)
LNAV MDA	1100-1	478 (500-1)	1100-1¾	478 (500-1¾)
CIRCLING	1100-1	470 (500-1)	1140-1½ 510 (600-1½)	1340-2¼ 710 (800-2¼)

EC-3, 16 APR 2026 to 14 MAY 2026

EC-3, 16 APR 2026 to 14 MAY 2026