

APP CRS	Rwy Ldg	4700
275°	TDZE	747
	Apt Elev	747

RNAV (GPS) RWY 27

DOWAGIAC MUNI (C91)

RNP APCH - GPS.

▼ Rwy 27 helicopter visibility reduction below 3/4 SM NA. VDP NA when using EKM altimeter setting.
▲ NA Circling Rwy 9 NA at night. Circling NA to Rwy 4 and 22. Obtain local altimeter setting on CTAF, when not received, use EKM altimeter setting and increase all MDAs 60 feet and LNAV visibility Cats C and D 1/2 SM, and Circling visibility Cats C and D 1/4 SM.

MISSED APPROACH:
 Climb to 2500 direct JUBLA and hold.

SOUTH BEND APP CON ★
118.55 257.8

UNICOM
122.8 (CTAF) 0

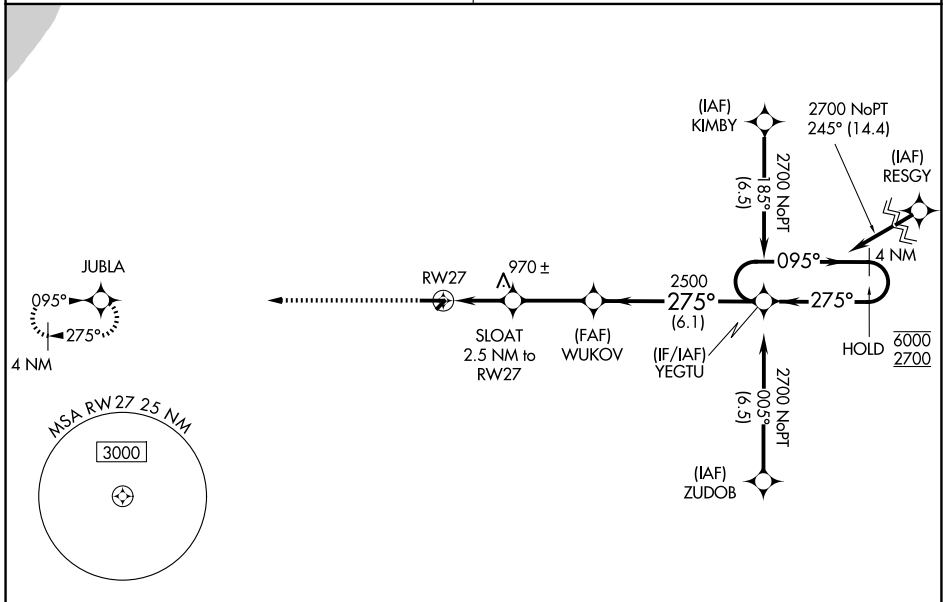

EC-1, 16 APR 2026 to 14 MAY 2026

EC-1, 16 APR 2026 to 14 MAY 2026

ELEV 747	TDZE 747
-----------------	-----------------

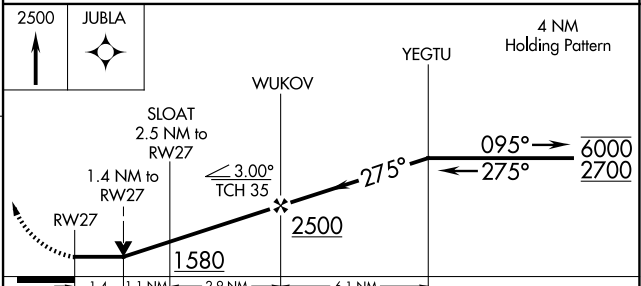
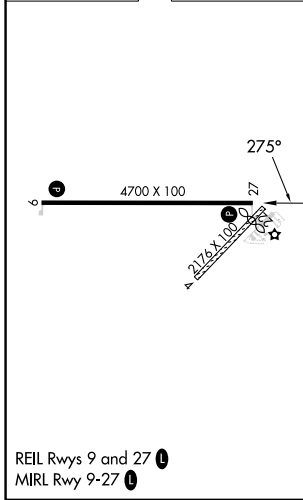

CATEGORY	A	B	C	D
LNAV MDA	1220-1	473 (500-1)	1220-1 3/8	473 (500-1 3/8)
CIRCLING	1300-1 553 (600-1)	1320-1 573 (600-1)	1320-1 1/2 573 (600-1 1/2)	1480-2 1/4 733 (800-2 1/4)