

WAAS CH <b>49040</b> <b>W26A</b>	APP CRS <b>255°</b>	Rwy Ldg TDZE Apt Elev	<b>3438</b> <b>186</b> <b>193</b>
--	------------------------	-----------------------------	---

# RNAV (GPS) RWY 26

TRACY MUNI (TCY)

RNP APCH.

Baro-VNAV NA when using Stockton altimeter setting. For uncompensated Baro-VNAV systems, LNAV/VNAV NA below -15°C or above 54°C. Circling NA southwest of Rwy 12-30. Circling Rwy 30 NA at night. Rwy 26 helicopter visibility reduction below ¾ SM NA. When local altimeter setting not received, use Stockton altimeter setting: increase LPV DA to 496 feet, increase LNAV/VNAV DA to 553 feet; increase all MDAs 60 feet and visibility LNAV Cat C ½ SM.

MISSED APPROACH: (Do not exceed 210K until OMWAP) Climb to 640 then climbing right turn to 3000 direct OMWAP and hold.

AWOS-3 <b>118.375</b>	NORCAL APP CON <b>123.85 278.3</b>	UNICOM <b>123.075 (CTAF)</b>
--------------------------	---------------------------------------	---------------------------------

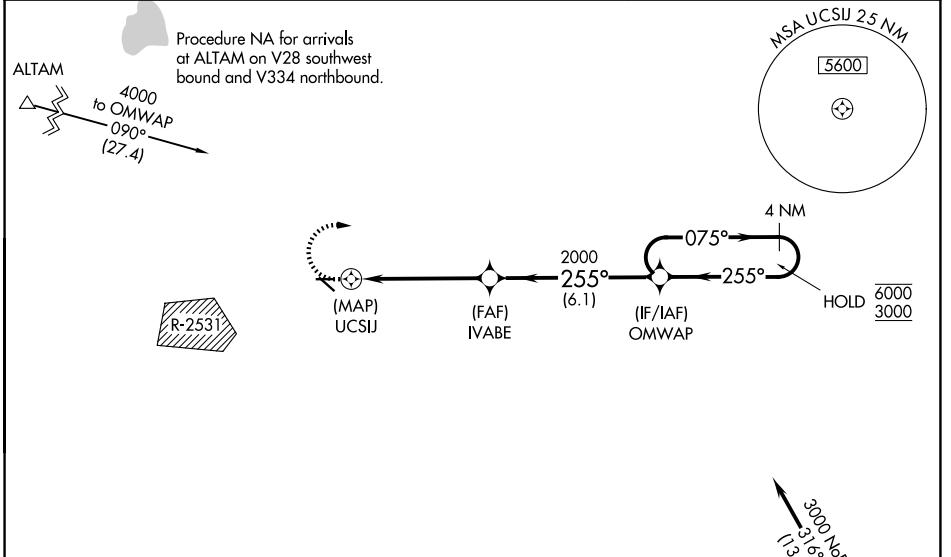

ELEV 193	TDZE 186
----------	----------

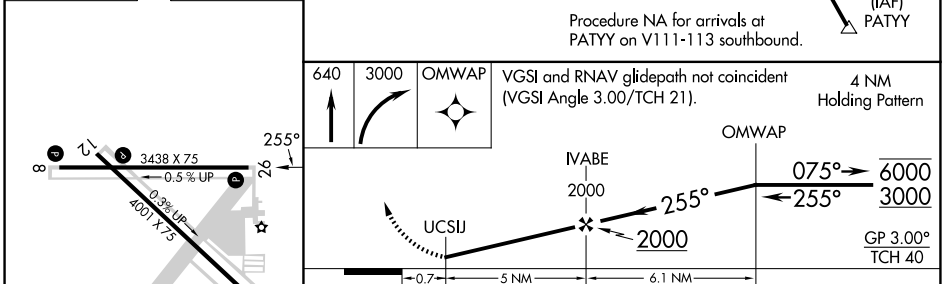

CATEGORY	A	B	C	D
LPV DA	436-7/8	250 (300-7/8)		NA
LNAV/VNAV DA	493-11/8	307 (300-11/8)		NA
LNAV MDA	540-1	354 (400-1)		NA
CIRCLING	580-1 387 (400-1)	660-1 467 (500-1)	660-1½ 467 (500-1½)	NA