

APP CRS 276°	Rwy Ldg 4400
	TDZE 1004
	Apt Elev 1004

RNAV (GPS) RWY 28

KENDALLVILLE MUNI (C62)

RNP APCH - GPS.

⚠ Rwy 28 helicopter visibility reduction below 1 SM NA. Straight-in Rwy 28 NA at night, Circling Rwy 28 NA at night. When local altimeter setting not received, use GWB altimeter setting and increase all MDAs 60 feet.

MISSED APPROACH: Climb to 3000 direct HIATT and on track 286° to BAGEL and hold.

AWOS-3P
119.925

FORT WAYNE APP CON
127.2 284.6

UNICOM
122.8 (CTAF) 1

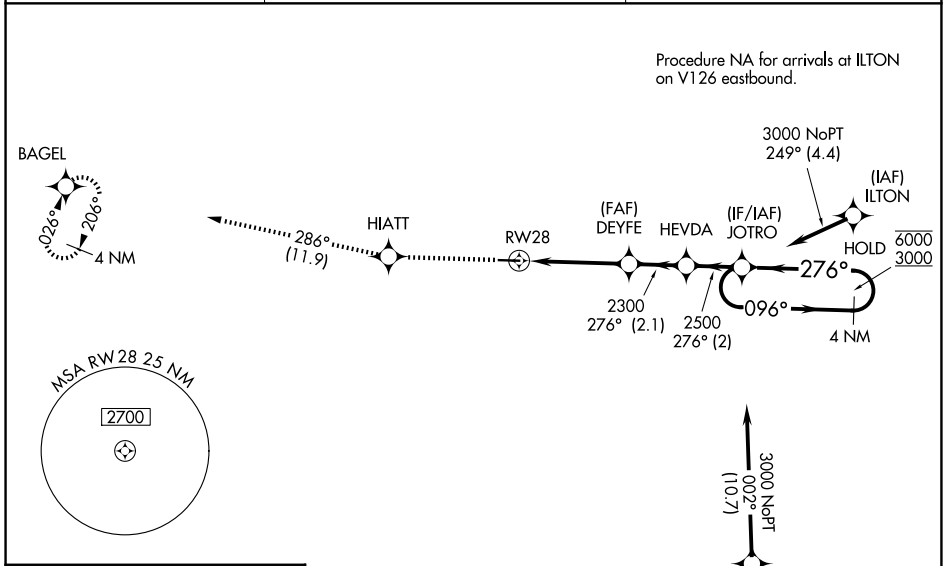

ELEV 1004	TDZE 1004
-----------	-----------

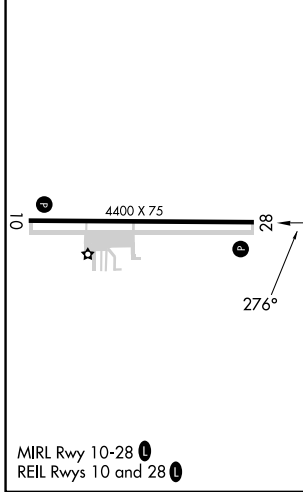

Procedure NA for arrivals at GAREN on V8 eastbound.

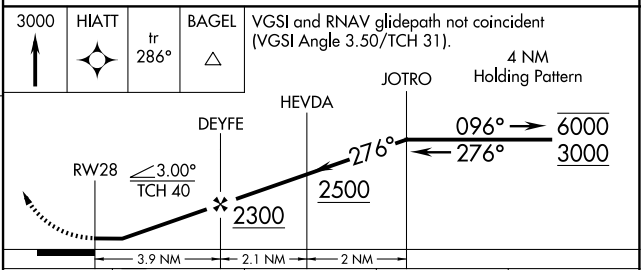

CATEGORY	A	B	C	D
LNAV MDA	1520-1	516 (600-1)	NA	
CIRCLING	1600-1	596 (600-1)	NA	

EC-2, 16 APR 2026 to 14 MAY 2026

EC-2, 16 APR 2026 to 14 MAY 2026