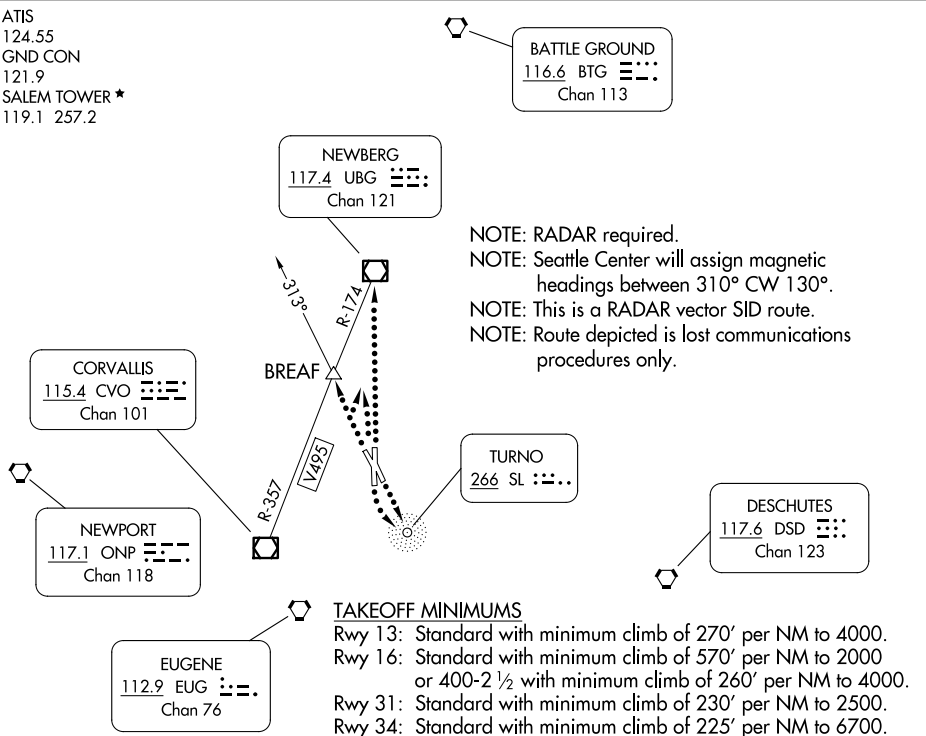

ATIS  
124.55  
GND CON  
121.9  
SALEM TOWER \*  
119.1 257.2

**TAKEOFF MINIMUMS**

Rwy 13: Standard with minimum climb of 270' per NM to 4000.  
Rwy 16: Standard with minimum climb of 570' per NM to 2000  
or 400-2 1/2 with minimum climb of 260' per NM to 4000.  
Rwy 31: Standard with minimum climb of 230' per NM to 2500.  
Rwy 34: Standard with minimum climb of 225' per NM to 6700.

NOTE: Chart not to scale.

**DEPARTURE ROUTE DESCRIPTION**

**TAKEOFF RUNWAYS 13, 31, 34:** Climb to assigned altitude and heading between 310° CW 130° from DER, thence . . . .

**TAKEOFF RUNWAY 16:** Climbing left turn to assigned heading between 340° CW to 130° from DER to assigned altitude, thence . . . .

. . . . expect RADAR vectors with Seattle Center to assigned route. Expect filed altitude 10 minutes after departure.

**LOST COMMUNICATIONS:**

If not in contact with Seattle Center after reaching 2000, continue climb to assigned altitude.

**TAKEOFF RUNWAYS 13 and 16:** (Runway 16 turn left) proceed direct to SL NDB thence on (assigned route) (ADF required).

**TAKEOFF RUNWAYS 31 and 34:** (Runway 31 turn right) proceed direct to UBG VOR/DME thence on (assigned route).

**HELICOPTERS ONLY - RUNWAYS 31 and 34:** (Runway 34 turn left) intercept and proceed outbound on the SL NDB 313° bearing to BREAF INT, thence on (assigned route) (ADF required).