

APP CRS	Rwy Ldg	5001
108°	TDZE	790
	Apt Elev	790

RNAV (GPS) RWY 11

FULTON COUNTY (R.C.R)

RNP APCH - GPS.

- ▼ Helicopter visibility reduction below 3/4 SM NA. VDP NA when using GSH altimeter setting.
- ▲ When local altimeter setting not received, use GSH altimeter setting: increase all MDA 100 feet and LNAV visibility Cats C/D and Circling Cats C/D 1/4 SM.

MISSED APPROACH: Climb to 3000 direct LOWTO and hold.

AWOS-3 118.775	SOUTH BEND APP CON ★ 132.05 257.8	UNICOM 122.7 (CTAF) 0
--------------------------	---	---------------------------------

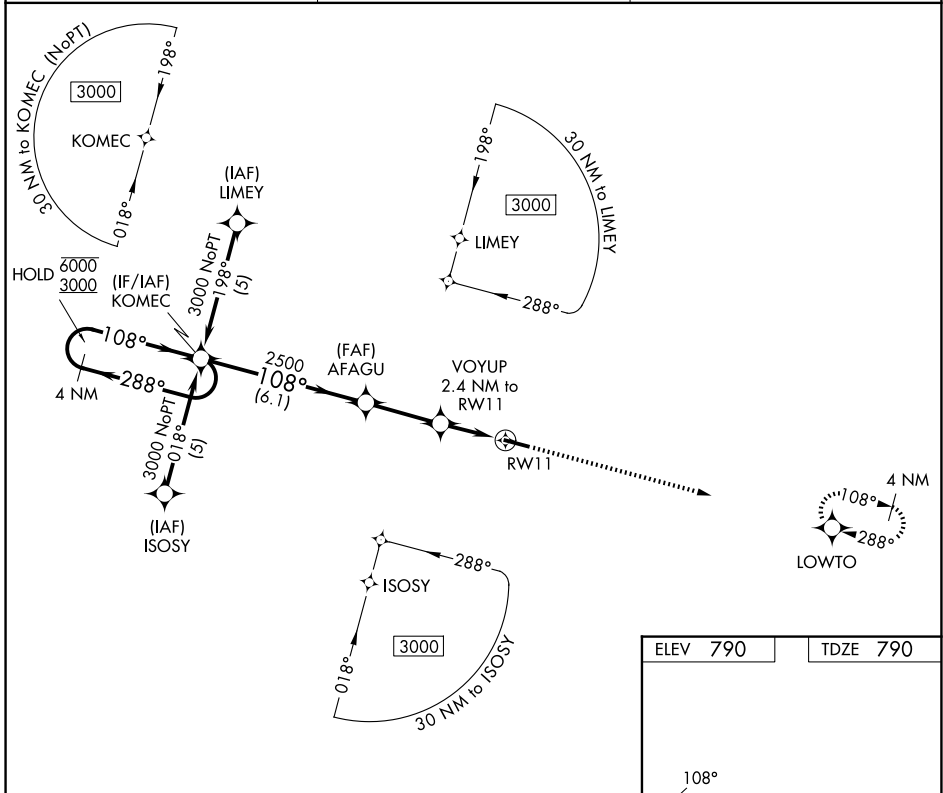

EC-2, 14 MAY 2026 to 11 JUN 2026

EC-2, 14 MAY 2026 to 11 JUN 2026

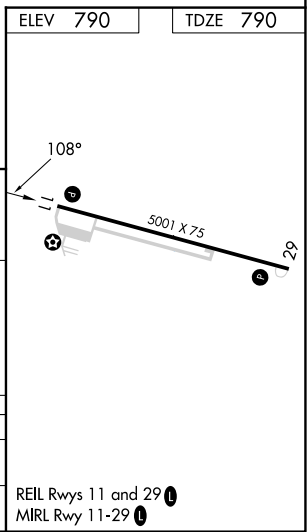
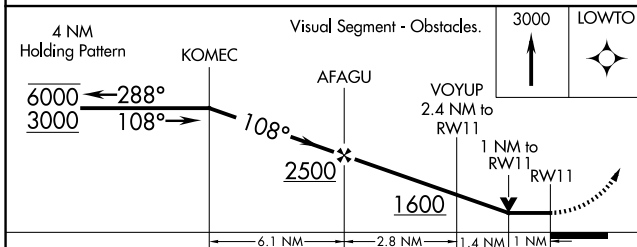

CATEGORY	A	B	C	D
LNAV MDA	1220-1	430 (500-1)	1220-1 1/4 430 (500-1 1/4)	1220-1 1/2 430 (500-1 1/2)
CIRCLING	1300-1 510 (600-1)	1380-1 590 (600-1)	1480-2 690 (700-2)	1620-2 3/4 830 (900-2 3/4)