

WAAS CH 58041 W11A	APP CRS 111°	Rwy Ldg 3200 TDZE 29 Apt Elev 29
--	------------------------	---

RNAV (GPS) RWY 11

BUCKLAND (BVK)(PABL)

RNP APCH.

Baro-VNAV and VDP NA when using Selawik altimeter setting. For uncompensated Baro-VNAV systems, LNAV/VNAV NA below -21°C or above 54°C.
When local altimeter setting is not received use Selawik altimeter setting: increase DA to 387 feet and all visibilities $\frac{3}{8}$ SM; increase all MDAs 120 feet and visibility Cat C $\frac{1}{4}$ SM.

MISSED APPROACH:
Climb to 3100 direct JAMUR and hold, continue climb-in-hold to 3100.

AWOS-3P 135.15	ANCHORAGE CENTER 119.2 263.0	KOTZEBUE RADIO 122.3	CTAF 122.9
--------------------------	--	--------------------------------	----------------------

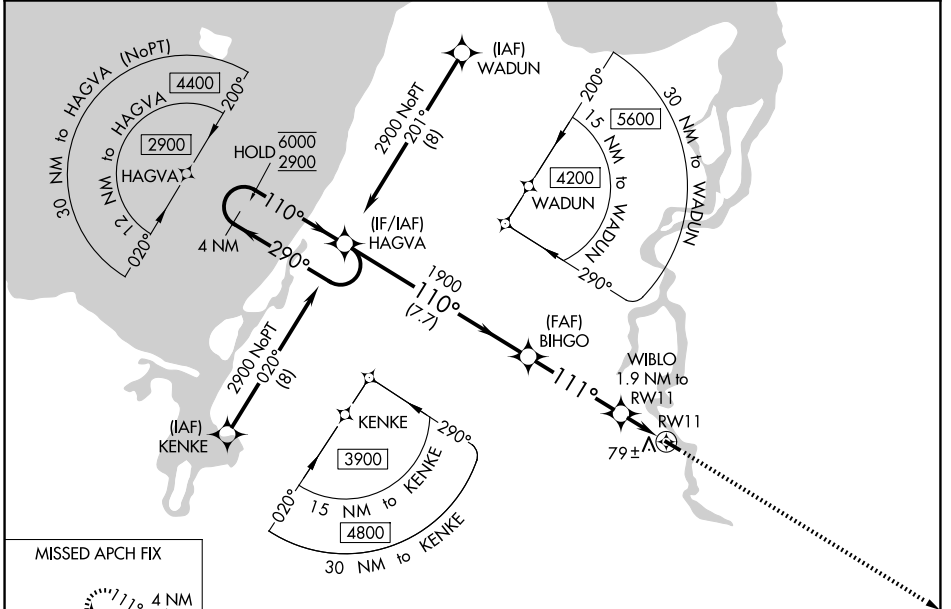

ELEV 29	TDZE 29
---------	---------

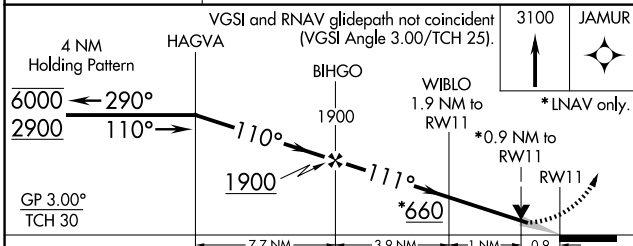

CATEGORY	A	B	C	D
LPV DA	279-1	250 (300-1)		NA
LNAV/VNAV DA	279-1	250 (300-1)		NA
LNAV MDA	340-1	311 (400-1)		NA
CIRCLING	540-1	511 (600-1)	640-1 $\frac{3}{4}$ 611 (700-1 $\frac{3}{4}$)	NA

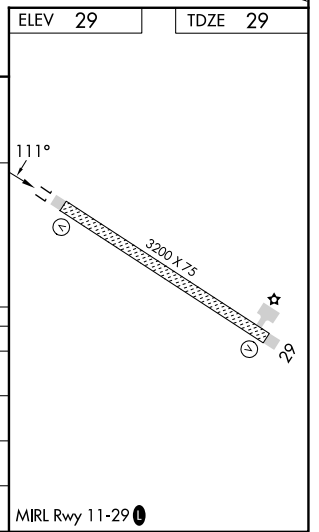

AK, 14 MAY 2026 to 09 JUL 2026

AK, 14 MAY 2026 to 09 JUL 2026