

LOC/DME I-JAV <b>110.5</b> Chan <b>42</b>	APP CRS <b>093°</b>	Rwy Ldg <b>11260</b> TDZE <b>668</b> Apt Elev <b>680</b>
---	------------------------	--

# ILS RWY 9R (CAT II & III)

## CHICAGO O'HARE INTL (ORD)

RNP APCH - GPS. From GIBNS.

DME or RADAR required. RADAR required for procedure entry at GIBNS.

Simultaneous approach authorized.

ALSF-2



MISSED APPROACH: Climb to 1200 then climb to 4000 on heading 085° and OBK VOR/DME R-124 to GRABL INT/OBK 26.9 DME/RADAR and hold.

D-ATIS <b>135.4 282.225</b>	CHICAGO APP CON <b>119.0 292.125</b>	O'HARE TOWER <b>126.9 348.0</b>	GND CON (TWR CENTER) <b>124.125</b> (TWR NORTH) <b>121.75</b> (OBND) <b>118.05</b> (TWR SOUTH) <b>121.9</b> (IBND) <b>226.675</b> (ALL TWRs)
--------------------------------	---	------------------------------------	---

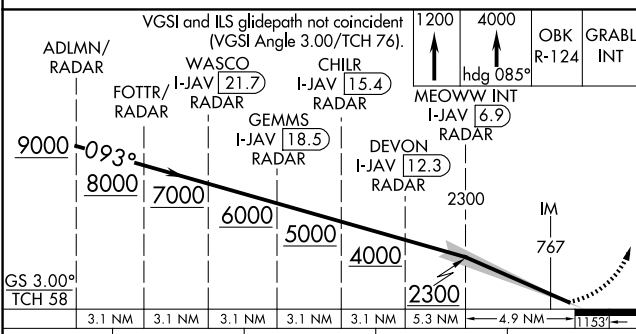
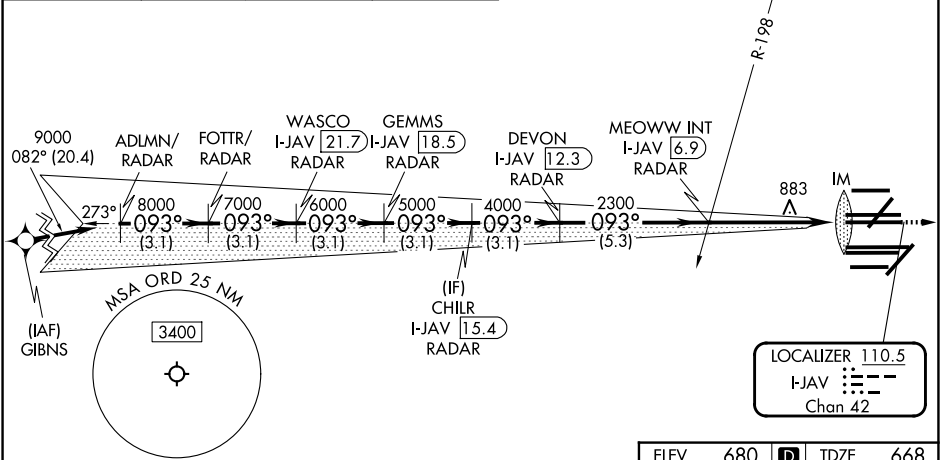
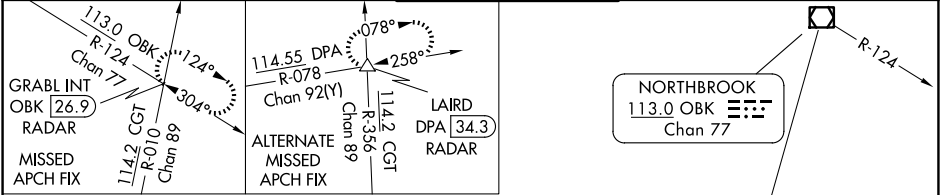

ELEV 680	<b>D</b>	TDZE 668
----------	----------	----------

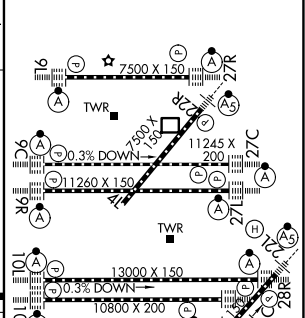

CATEGORY	A	B	C	D
S-ILS 9R	CAT II RA 99/12 100 DA 768			
S-ILS 9R	CAT III RVR 06			

**CATEGORY II & III ILS - SPECIAL AIRCREW & AIRCRAFT CERTIFICATION REQUIRED**

HIRL all rwys  
TDZL/RCLS all rwys except 4L