

WAAS CH <b>65899</b> <b>W11A</b>	APP CRS <b>114°</b>	Rwy Idg TDZE Apt Elev	<b>3601</b> <b>6</b> <b>6</b>
--	------------------------	-----------------------------	-------------------------------------

# RNAV (GPS) RWY 11

MERRITT ISLAND (COI)

**RNP APCH.**  
 ▼ Rwy 11 helicopter visibility reduction below 1 SM NA. When local altimeter setting not received, use Melbourne altimeter setting and increase LPV DA to 329 and all MDA 40 feet, increase LPV all Cats visibility 1/8 mile. Night landing: Rwy 11 NA.  
 ▲ MISSED APPROACH: Climb to 3000 direct YONUS and on track 190° to MLB VOR/DME and hold.

AWOS-3PT <b>119.025</b>	ORLANDO APP CON <b>134.95 281.425</b>	UNICOM <b>122.975 (CTAF) 0</b>
----------------------------	--	-----------------------------------

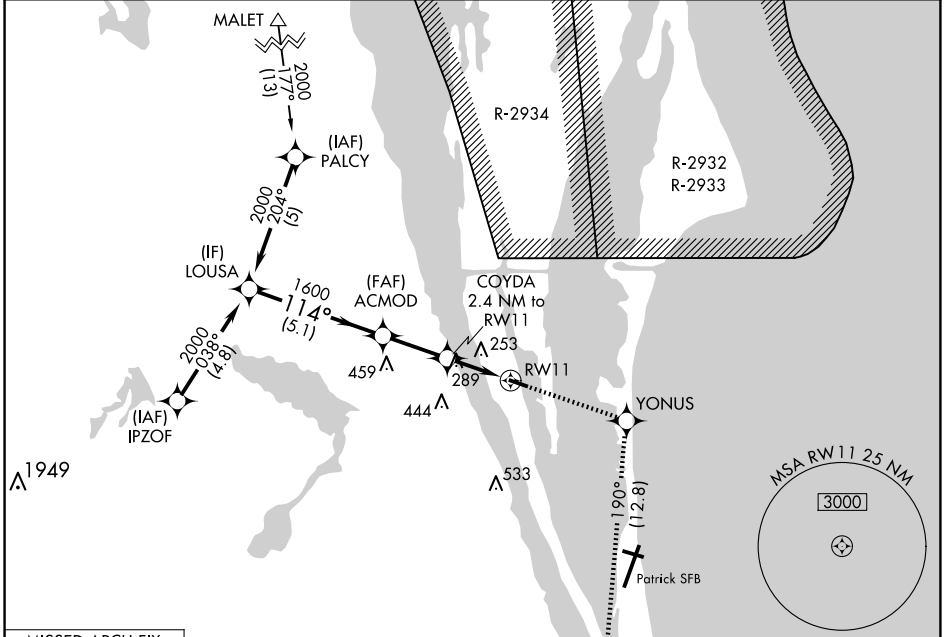

Procedure NA for arrivals on MLB VORTAC airway radials 276 CW 329.

ELEV 6	TDZE 6
--------	--------

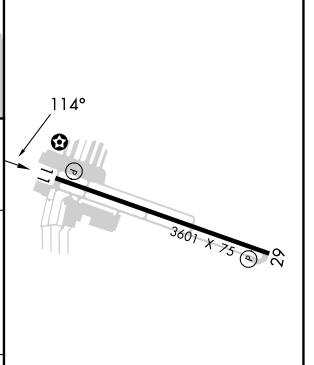
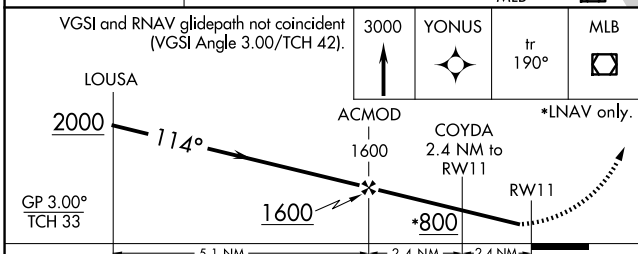

CATEGORY	A	B	C	D
LPV DA	291-1	285 (300-1)		NA
LNAV MDA	600-1	594 (600-1)		NA
CIRCLING	600-1 594 (600-1)	620-1 614 (700-1)		NA

MIRL Rwy 11-29 0