

FLORY N38°40.89' W97°38.70' NOTAM FILE SLN.
 NDB (LOMW) 344 SL 350° 6.5 NM to Salina Rgnl. 1318/7E.

WICHITA

FORT RILEY N38°58.21' W96°51.67' NOTAM FILE FRI.
 (T) VORW 109.4 FRI 036° 6.7 NM to Marshall AAF. 1228/6E. VOR unmonitored 0600–1400Z† Mon;
 0700–1400Z† Tue–Thu; 2200Z† Fri – 0600Z† Sat, wkends and hol.

KANSAS CITY
 L-101

FORT SCOTT MUNI (FSK)(KFSK) 4 SW UTC-6(-5DT) N37°47.90' W94°46.16'
 918 B NOTAM FILE ICT
RWY 18-36: H4403X75 (ASPH) S-24 PCN 9 F/D/X/T MIRL
 0.3% up S

KANSAS CITY
 L-101, 16F
 IAP

RWY 18: REIL. VASI(V4L)—GA 3.0° TCH 33'. Tree.
RWY 36: REIL. PAPI(P2L)—GA 3.0° TCH 44'. Tree.
SERVICE: FUEL 100LL, JET A1+ LGT ACTIVATE MIRL Rwy 18-36,
 VASI Rwy 18, PAPI Rwy 36 and REIL Rwy 18 and Rwy 36—CTAF.
AIRPORT REMARKS: Attended Mon-Sat 1400–2300Z†. Deer fence around
 airport perimeter. Ground drops rapidly 250' from Rwy 18 end. NOTE:
 See Special Notices Section—Aerobatic Practice Areas.
AIRPORT MANAGER: 620-223-5490
WEATHER DATA SOURCES: AWOS-3P 124.425 (620) 215-5899.
COMMUNICATIONS: CTAF/UNICOM 122.8
 Ⓡ KANSAS CITY CENTER APP/DEP CON 125.55
CLEARANCE DELIVERY PHONE: For CD ctc Kansas City ARTCC at
 913-254-8508.
RADIO AIDS TO NAVIGATION: NOTAM FILE COU.
BUTLER (VH) (H) VORTAC 115.9 BUM Chan 106 N38°16.32'
 W94°29.30' 198° 31.4 NM to fld. 890/7E.
 VOR unusable:
 083°-093° byd 40 NM blo 13,500'
 249°-259° byd 40 NM blo 18,000'
 295°-305° byd 49 NM

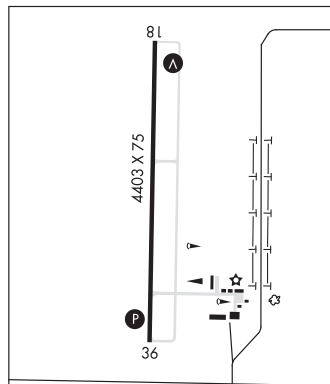

FOWLER (18K) 0 E UTC-6(-5DT) N37°23.06' W100°11.17'
 2483 NOTAM FILE ICT
RWY 03-21: 2310X100 (TURF)
RWY 03: Road.
RWY 21: Road.

WICHITA

AIRPORT REMARKS: Unattended. Rwy 03 +28' poles ltgd p-line aprx 450' S of SW end of rwy. Rwy 21 mkd with small red
 reflectors: solar lights and red cones.
AIRPORT MANAGER: 620-338-1576
COMMUNICATIONS: CTAF 122.9
CLEARANCE DELIVERY PHONE: For CD ctc Kansas City ARTCC at 913-254-8508.

FREDONIA (1K7) 2 N UTC-6(-5DT) N37°34.84' W95°50.23'
 882 B NOTAM FILE ICT
RWY 17-35: H4557X60 (CONC) LIRL

KANSAS CITY
 L-15E

RWY 17: Pole.
RWY 35: Thld dspld 541'.
AIRPORT REMARKS: Unattended. Wildlife on and invof arpt. Rwy 17 nstd
 NPI mkg, no thld bar present. Rwy 35 nstd small bsc markings. A
 drainage ditch 70' left of AER 17 runs parallel 700'.
AIRPORT MANAGER: 620-378-2231
COMMUNICATIONS: CTAF 122.9
CLEARANCE DELIVERY PHONE: For CD ctc Kansas City ARTCC at
 913-254-8508.
RADIO AIDS TO NAVIGATION: NOTAM FILE CNU.
CHANUTE (L) DME 109.2 CNU Chan 29 N37°37.57'
 W95°35.61' 257° 11.9 NM to fld. 1085.

